

t-max

GENERAL CATALOGUE

www.t-max.com.tr



CONTENTS

HOPPER LOADERS	03-12
DRYING AND DEHUMIDIFIERS	13-28
GRANULATORS AND RECYCLING	29-38
CT SHEDDERS.....	39-45
MOBILE MIXERS	46-48
VERTICAL MIXERS	49-51
MOBILE MATERIAL BINS	52-53
CONVEYORS AND SEPERATORS	54-63
METAL SEPARATORS.....	64-67
MAGNETS.....	68-70
DRAWER TYPE MOLD RACKS	71-76
DOSING AND MIXERS.....	77-85
PET CRYSTALIZER	86-89
COOLING AND HEATING UNITS.....	90-97
TEMPERATURE CONTROL UNITS	98-99
THERMOREGULATOR UNITS.....	100-108
CYCLONE DUST COLLECTORS	109-112
COMPONENTS FOR VACUUM AND MATERIAL LINES	113-117
MONO AND DOUBLE CHAMBER SILO AND SILO FEEDING UNITS	118-119
MULTI-FLOW BLENDING SILOS	120-122
ALUMINUM SILOS	123-140
MODULAR SILOS	141-146
ECO EMPTYING STATION FOR OCTABIN AND BIG BAG	147-173
MULTI MATERIAL FEEDING AND WEIGHING UNITS	174-176
BIG-BAG STAND EMPTYING FRAME	177-179
BAG OPENING AND EMPTYING MACHINE-BAGOMAX	180-184



HOPPER LOADERS

Hopper Loaders

TAL-6U

Euro design with stainless stainless hopper to keep material from pollutions, in addition, it has an attractive and polished appearance, and a sound proof motor cover to reduce noise level. And it is convenient by using a detachable control panel.

With more that 30 years experience and the spirit of innovation and pursuing for excellence, we have been developing various top quality hopper loaders for conveying all kinds of plastic materials. Stainless steel hopper and high efficiency vacuum blower are adopted for all those machines They are also equipped with motor overload relay and material shortage alarm. Those hopper loaders are light-weighted and reliable, and also they are featured with superior suction power, easy installation and convenient operation.



TAL-6U

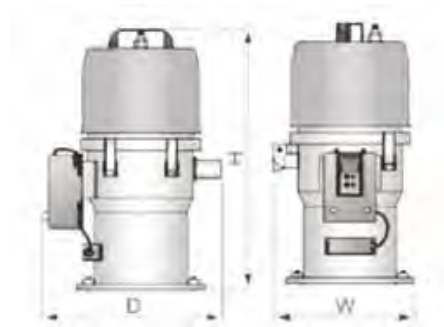

TAL-U

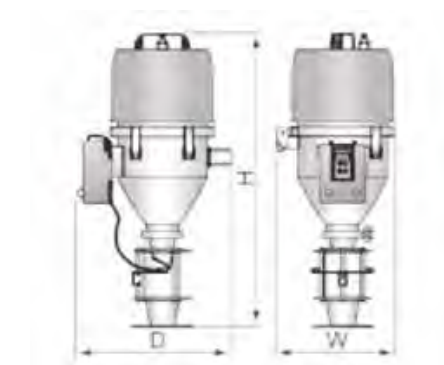

TAL-U-E

TECHNICAL FEATURES

Model	TAL-1.5U	TAL-3U	TAL-6U	TAL-12U	TAL-1.5U-E	TAL-3U-E	TAL-6U-E	TAL-12U-E
Motor Power (kW)	0.42	0.42	1.15	1.15	0.42	0.42	1.15	1.15
Vacuum Connection Diameter (inch)	1.5"	1.5"	1.5"	1.5"	1.5"	1.5"	1.5"	1.5"
Material input diameters (Inch)	1.5"	1.5"	1.5"	1.5"	1.5"	1.5"	1.5"	1.5"
Capacity (kg/hour)	150	200	300	400	150	200	300	400
Hopper Volume (liter)	1.5	3	6	12	1.5	3	6	12
Power Supply	1Ø, 230V, 50Hz							
Reverse Cleaning Kit								
Air Accumulator								
Dimensions								
Height H (mm)	525	555	645	745	670	740	800	935
Width W (mm)	270	305	340	340	260	305	340	340
Depth D (mm)	325	370	410	410	325	370	410	410
Weight	10	11	12	14	11	13	16	18

Plus:

- 1) Device that can auto-cleaning filter screen (use C to refer to, for example: TAL-3U-C...) use 4-6lg/cm² pressure air.
- 2) Air accumulator (apply to TAL-6U,12 model only, use A to refer to, for example: TAL-6U-CA...)
- 3) Conveying capacity test standard: (height:4m)

FEATURES

- » TAL-1.5U TAL-12U uses carbon brush motor with high rotation speed, large air flow. It is easy to install and move the relatively small machine.
- » Microprocessor control is easy to operate. Control the machine accurately with multiple alarm indicators.
- » Indicators of motor started assurance.
- » European two-proportion-valve electrical control function (optional)
- » Hopper and Base can be adjusted to arbitrary direction.
- » TAL-U use the magnetic switch while TAL-U-E use the photoelectric proximity switch. It is sensitive and in stable quality.
- » All models are equipped with hinged hopper cover convenient to clean the filter.
- » TAL-3U/6U and other larger models can be equipped with outer dia 275mm base, and mounted with hopper dryers THD-40U/THD-12 and other larger models (installation size: 180mmx180mm)
- » TAL-1.5U model equipped with outer dia 220 mm base can be mounted with THD-20U/40U (installation size 140mmx140mm)
- » TAL-U series are all with cloth filter, auto spray cleaning dust removal device. Spray cleaning accumulators are optional to be used with TAL-6U and other larger models in order to reduce the manual cleaning times, and keep the equipment operation function.
- » Standard insulated European aggregate bin TCH-6U 12U/24U are optional. Equipped with aggregate bin under the hopper with magnetic switch, the loader can be directly mounted to the injection molding machine. Upgraded to European Safety Circuit, add "CE" to the model.

Vacuum-Hopper Loaders

The TAL-300 Series use a high-speed motor in this lightweight and compact unit. With superior suction power and easy installation it is particularly suitable for conveying new materials. The TAL-400 series use a high voltage inductive motor with low noise level and long life span. It also has an automatic reversal dust cleaning device.



TAL-400C

FEATURES

- » Easy operation and maintenance
- » Stainless steel hopper
- » Motor protective device
- » Buzzer is an option for material shortage alarm.
- » Auto reversal filtering device and cloth-made filter are standard accessories.
- » TAL-300E equips with photo sensor and suitable to install on the material inlet of moulding machine.

TECHNICAL FEATURES

Model	TAL-300C	TAL-300G	TAL-300E	TAL-400C
Motor Type	Monophase	Monophase	Monophase	Three-phase
Motor Power (kW)	1150	1150	1150	750
Transportation Capacity (kg/hour)	180	180	180	250
Hopper Volume (liter)	6	6	6	6
Transportation Pipe	Φ38	Φ38	Φ38	Φ38
Input Voltage	1Φ, 230V,50Hz			3Φ,400V,50Hz
Raw Material Level Control	With Flap	With Flap	With sensor	With Flap
Textile Filter	Standard		Standard	Standard
Automatic Cleaning Function			Standard	Standard
Dimensions				
Height (mm)	595	595	730	670
Width (mm)	300	300	300	280
Depth (mm)	395	395	365	450
Weight	13	12	17	26



TAL-300E

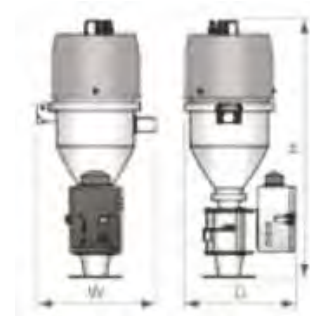

TAL-300E

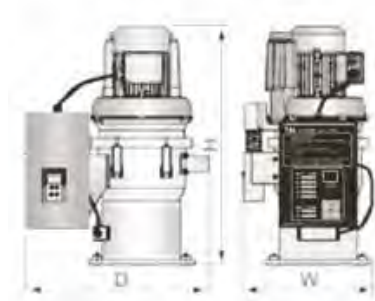

TAL-400C

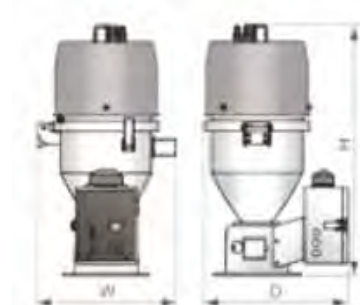

TAI-300C

Seperate-Vacuum Hopper Loaders

TAL-800G

Separate-vacuum hopper loaders are suitable for conveying material over long distance. The material hopper is installed away from the main unit and use a stainless-steel hopper to eliminate material contamination. Superior suction power is continuously available from the highly efficient vacuum blower. Each model is completed with motor overload protector to prolong its life, and is also fitted with material shortage alarm.



TAL-800G



TAL-700G+TMH-6L



TAL-800G+TMH-6L

FEATURES

- » Separate design of main unit and hopper receiver allows a great level of convenience when in use.
- » Stainless hopper receiver to eliminate contamination.
- » Microprocessor controlled for ease of use.
- » Digital display clearly show operating status.
- » Motor overload protector ensures long motor life.
- » Audible material shortage alarm.
- » Filter designed for easy cleaning.
- » Observation window to check air filter status.
- » Vacuum hopper receiver (TMH type) can be mounted directly to machine hopper; glass-tube hopper receiver (TVH type) can be mounted directly to machine throat.



Glass Tube Chamber



TAL-700G+TMH-6L



TAL-800G+TMH-6L

TECHNICAL FEATURES

Model					Hopper Receiver			Weight (kg)	Transportation Pipe Diameter (inch)	Transportation Capacity (kg/hour)
Model	Motor Type	Motor Power (kW)	Dimensions YxExB (mm)	Weight (kg)	Applicable Model	Capacity (L)	Dimensions YxExB (mm)			
TAL-700G	Monophase	1.15 (1Φ)	710x540x390	18	TMH-6L	6	450x260x300	6	1.5"	300
					TVH-6L		585x260x330	7		
TAL-800G	Three-phase	0.85 (3Φ)	370x620x420	40	TMH-6L	6	450x260x300	6	1.5"	300
					TVH-6L		585x260x330	7		
TAL-800G2	Three-phase	1.6 (3Φ)	710x540x390	47	TMH-12L	12	530x310x350	7	1.5"	500
					TVH-12L		680x310x350	10		
TAL-900G	Three-phase	0.85 (3Φ)	620x365x600	50	TMH-6Lx1	6	450x260x300	6	1.5"	500
							585x260x300	7		
							450x260x300	6		
							585x260x300	7		
TAL-900G2	Three-phase	1.6 (3Φ)	680x375x740	56	TMH-12Lx1	12	530x310x350	7	1.5"	700
							680x310x350	10		
							530x310x350	7		
							680x310x350	10		

- "2" stands for 2HP blower.
- "G" stands for separate design of hopper receiver (s) and main unit.
- "TMH" stands for vacuum hopper receiver, "TVH" stands for glass-tube hopper receiver.
- Test condition of conveying capacity: vertical conveying height: 4m
- Power supply 3Φ, 400V, 50Hz for all models except TAL-700G (1Φ, 230V, 50Hz)



TAL-700G



TAL-800G/800G2

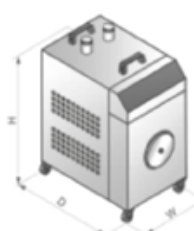

TAL-900G/900G2

Euro Series-High Capacity Hopper Loaders

TAL-UG

The TAL-US series separate-vacuum hopper loaders are based on the established design and now are featured with more attractive appearance better performance, and improved ease of operation. The whole range comprises of seven models equipped with vacuum blower from 1HP to 15HP Economy modes can be offered on request. The TAL-US series separate-vacuum hopper loaders have all features that come with THL-US series There is also double-stage blower available as an option. Different model of hopper is available for each individual output capacity needs especially suitable for 30% and 100% powder loading.



TAL-UG



THR-U

FEATURES

- » Data backed up on EEPROM in case of power failure.
- » It consists of a cyclone dust separator and a dust collective bin to effectively reduce the load of filter. It can be equipped with two proportional valve.
- » Stainless steel mesh filter as standard. Optional filter cleaning device available for automatic cleaning and air accumulator to TAL-12U-C CE and above.
- » Economy models can be offered on request. (cloth filter as standard second filter is removed)
- » Provide both standard and optional heat-insulative Euro collective hopper TAL- 6U / 12U / 24U for selection (except for TAL-UGP series which will use special collective hopper)
- » Based on customer's demand, the cloth bag type and plate-type filters can be selected to the machine.
- » The air accumulator and self-cleaning device are standard equipment
- » On customer's demand, TAL- UG main unit (3.5HP and above) can be equipped with either single stage or double stage blower.
- » Upon request, it can be built to comply with worldwide electrical safety standards.



THR-U

THR-U-E



TECHNICAL FEATURES

Model	Main Unit			Hopper Receiver				Loading Pipe Diameter	Air Suction Pipe Diameter (inch)	Loading Capacity (kg/hour)
	Motor Power (kW)	Dimensions HxWxL (mm)	Weight (kg)	Applicable Model	Capacity (L)	Dimensions HxWxL	Weight (kg)			
TAL-1HP-UG	0.85(3φ)	1205x350x530	46	THR-6Ux1	6	420x285x360	6	1.5"	1.5"	300
		960x350x405	39	THR-6UEx1		600x275x360	8			
TAL-2HP-UG	1.6(3φ)	1205x350x530	46	THR-12Ux1	12	470x315x400	7	1.5"	1.5"	500
		960x350x405	39	THR-12U-Ex1		700x315x400	12			
TAL-3.5HP-UG	3(3φ)	1380x490x570	73	THR-24Ux1	24	690x315x400	9	2"	2"	750
		1110x420x545	62	THR-24Ux1		690x315x400	13			
TAL-5HP-UG	3.7(3φ)	1380x490x570	74	THR-24U-Ex1	24	1120x360x400	9	2"	2"	1000
		1110x420x545	65	THR-24U-Ex1		1120x360x400	13			
TAL-7.5HP-UG	3.5(3φ)	1830x585x675	156	THR-36Ux1	36	963x315x400	11	2"	2.5"	1200
		1200x460x580	112							
TAL-10HP-UG	7.5(3φ)	1830x585x675	160	THR-36Ux1	36	930x315x400	11	2"	2.5"	1600
		1200x460x580	116							
TAL-15HP-UG	11(3φ)	2100x680x800	228	THR-48Ux1	48	975x350x485	15	2.5"	3"	2000
		1260x560x800	210							

- "D" stands for double stages, "124 indicates 1 to 4 conveying function.
- Add "E" to the model, if the machine includes glass tube, photoelectric switch and check valve.
- Add "P" to the model, if the hopper's interior is polished.
- TAL-3.5HP-UG and other larger models can include vacuum breaker valve to improve the conveying capacity
- Noise level is 75dB.
- Condition of testing conveying capacity: plastic raw material granule density 0.65, dia 3-5mm, vertical conveying height 4m, horizontal conveying height 5m.
- Voltage: 3φ, 400V, 50Hz

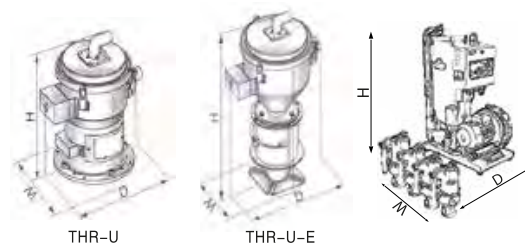

THR-U

THR-U-E

“One-to-Six” seperate hopper loaders

TAL-UG

“One-to-Six” seperate hopper loaders are designed and developed on the basis of original Euro seperate-vacuum hopper loaders. They feature more functions, easy to operate, and convenient to install. This model, equipped with a high pressure blower and six THR-U type Euro central vacuum hoppers, is applicable to dehumidifying and drying unit (dehumidifying dryer “TDD”) or storage hopper to process plastic materials. Besides, it can also realize the “One-to-Six” way of conveying material to different molding machines or hoppers to greatly lower the cost.



TAL-UG

FEATURES

- » “One-to-six” hopper loader can greatly lower the cost
- » WATCHDOG easy for trouble shooting
- » The dust collective chamber features a cyclone separator and a dust collective bin to effectively reduce the load of the filter.
- » To ensure smooth material conveying, hopper receiver has diaphragm valve equipped on.
- » Main unit equips with faults and motor overload indicators to show fault fast.
- » CE safety plug ensures safe and reliable operation
- » Universal mounting bracket for hopper receiver with max, adjustable can be supplied as an option.
- » Optional collective hopper can be directly mounted on the moulding machine, when working with a glass-tube.

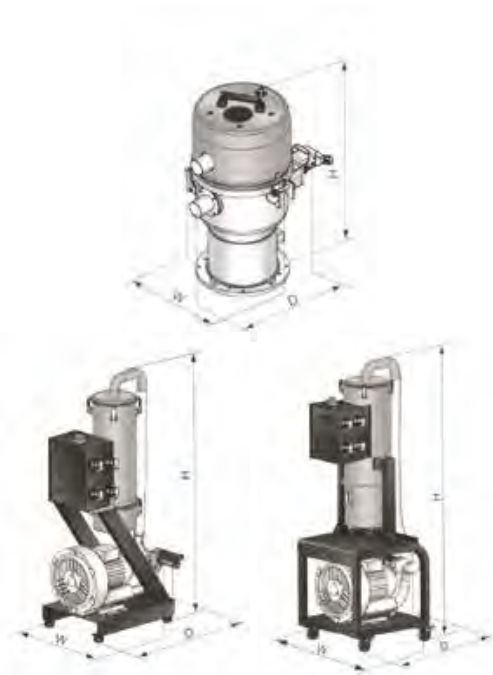

TECHNICAL FEATURES

Model	Main Unit			Hopper Receiver				Loading Pipe Diameter (mm)	Air Suction Pipe Diameter (inch)	Loading Capacity (kg/hour)
	Motor Power (kW)	Dimensions HxWxL	Weight (kg)	Applicable Model	Capacity (L)	Dimensions HxWxL	Weight (kg)			
TAL-3.5HP-UGS	3(3Ø)	1380x490x570	73	THR-24Ux1	24	690x315x400	9	2"	2"	750
		1110x420x545	62	THR-24Ux1		690x315x400	13			
TAL-5HP-UGS	3.7(3Ø)	1380x490x570	74	THR-24U-Ex1	24	1120x360x400	9	2"	2"	1000
		1110x420x545	65	THR-24U-Ex1		1120x360x400	13			
TAL-7.5HP-UGS	5.5(3Ø)	1830x585x475	156	THR-36Ux1	36	963x315x400	11	2"	2.5"	1200
		1200x460x580	112							
TAL-10HP-UGS	7.5(3Ø)	1830x585x675	160	THR-36Ux1	36	930x315x400	11	2"	2.5"	1600
		1200x460x580	116							
TAL-15HP-UGS	11(3Ø)	2100x680x800	228	THR-48Ux1	48	975x350x485	15	2.5"	3"	2000
		1260x560x800	210							

- “D” denote as double stage blower. (“126” denote as one to six receiver system)
- “E” denote as machine direct mounted receiver (glass type).
- For polished inside hopper, add “P” at model behind.
- Vacuum breaking valve to protect the blower.
- Noise level is 75dB.
- Condition of testing conveying capacity: plastic raw material granule density 0.65, dia 3-5mm, vertical conveying height 4m, horizontal conveying height 5m.
- Voltage: 3Ø, 400V, 50Hz

**DRYING AND
DEHUMIDIFIERS**



Hopper Dryer

THD-50

THD series hopper dryers offer an effective and low-cost method for plastic material drying. Hot air is used to dry wet materials due to moisture absorption during packaging, transportation, and recycling. They can be directly mounted on the moulding machine for quick drying and space saving.

For this series, hot air blows evenly from bottom to the top (both TDH-800 and TDH-1000 have down-blowing air pipe and accessible door for easy material clearance) of the hopper with capacity ranging from 12 kg to 1000 kg. All models can be supplied with optional 24 hours auto start / stop timer.



THD-50

FEATURES

- » Adopt hot air diffuser to gain an even hot air flow to improve drying efficiency.
- » Unique hot air inlet elbow design can prevent dust pilling up at bottom of the pipe heaters so to avoid burning.
- » All material contact surfaces are made of stainless steel to eliminate material contamination
- » Separable hopper base provides easy Access to hopper tank for the convenience of material changing and cleaning.
- » Proportional deviation indicative temperature controller for accurate temperature control.
- » Overheat protectors to prevent accidents by human error or manchanical faults.
- » Standard aluminum bases are equipped to all models in the series.
- » Overheat indicating light, motor contactor and overload realy are equipped Standard, to all models except for Economy type.
- » Exposed power switch is equipped, to all models except for Economy type.
- » Timer and double insulated hopper are available as options.
- » More optional accessories: "L" "A" type flor stand, dried-material suction box, hopper magnet, magnetic base, hot air recycler, blower inlet filter, exhausted air fitler, and cyclone dust separator.

OPTIONS :



Cyclone Dust Separators:

Effectively filters 90% dust contain air which is discharge from dryer so to avoid air pollution.



Exhaust Air Filters:

Effectively filter 80% dust contain air which is discharged from dryer so to avoid air pollution.



Hot Air Recycler:

Works with hopper dryer to make the hot air form a semi-hermetic circulated loop and has features as follows

Hot air recycling and circulating to avoid indoor temperature rising up Keep air in factory clean and ensure good product quality.

Heating by fast how air circulation can low down energy consumption by 40%.



Magnetic Bases:

Made of aluminum with built-in hopper magnet, can effectively separate metal scraps out so to avoid material contamination.

TECHNICAL FEATURES

Model	THD-12	THD-25	THD-50	THD-75	THD-100	THD-150	THD-200	THD-300	THD-400	THD-500	THD-600	THD-800	THD-1000
Heating Power (kW)	2.4	3	4.5	6.6	6.6	6.6	12	15	18	19.5	21	24	36
Power (kW)	0.075	0.017	0.017	0.2	0.2	0.2	0.33	0.33	0.41	0.41	0.55	0.55	1.1
Revolution (r/minute)	—	—	—	—	2.4	2.4	2.4	2.4	2.4	2.4	2.4	2.4	2.4
Drying Volume (lt)	20	40	80	120	160	230	300	450	600	750	900	1200	1500
Capacity (kg)	12	25	50	75	100	150	200	300	400	500	600	800	1000
A (mm)	Φ325	Φ385	Φ470	Φ530	Φ595	Φ595	Φ750	Φ750	Φ910	Φ910	Φ910	Φ960	Φ960
B (mm)	660	725	840	900	955	955	1230	1230	1365	1365	1365	1420	1420
C (mm)	865	1015	1145	1240	1340	1580	1750	1985	2105	2530	2530	2700	3000
D (mm)	750	925	1045	1150	1340	1605	1480	1480	1840	1840	2015	2240	2470
E (mm)	360	405	490	550	605	605	770	770	915	915	950	600	600
F (mm)	370	460	520	620	725	970	975	1220	1220	1400	1545	540	540
H (mm)	110	215	220	220	226	226	258	258	302	302	302	1550	1845
I (mm)	170	170	170	170	166	166	158	158	222	222	222	222	222
G (mm)	375	410	380	475	470	470	550	550	775	775	775	950	950
K/L (mm)	150	150	150	150	220	220	257	257	345	345	345	345	345
M (mm)	Φ55	Φ55	Φ55	Φ55	Φ90	Φ90	Φ90	Φ90	Φ105	Φ105	Φ105	Φ105	Φ105
Net Weight (kg)	22	34	45	56	68	78	110	152	170	192	280	380	650

Note:

- » If there is Autotimer, add "T" to the model designation.
- » If equipped with magnetic aluminum base, add "M" to the model designation.
- » If there is double insulated layer, add "I" to the model designation.
- » If it is 180 high temp. model, add "H" to the model designation
- » If it has single phase voltage, add "S" to the model designation.
- » The capacity is based on plastic material of 0.65 in density and 3-5 mm diameter.

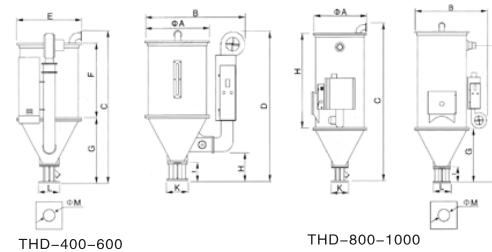

THD-400-600

THD-800-1000

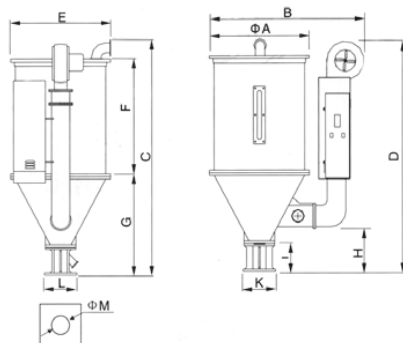

THD-400-600

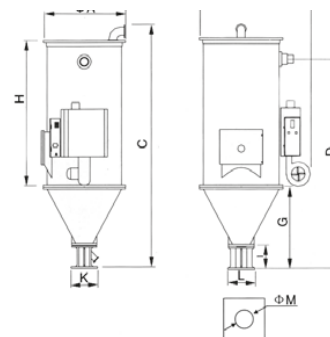

THD-800-1000

Drying & Conveying

TDL

The TDL series of drying loaders integrate plastic drying and loading injection moulding machine which are placed in height limited workshop. This combination offers a group of standard micro-switch hoppers which can be used to load dried materials. Besides, TAL-900G is available to realize the two-stage loading function.

FEATURES

- » Various models for customer to choose freely.
- » Takes little space and easy for transportation and replacement.
- » Adopts proportional deviation temp. Indicating controller which controls the temp. Accurately.
- » Stainless steel hopper ensures no material pollutions.
- » Equipped with alarming light to show faults at once.
- » Hopper separated from its base, ensures cleaning conveniently.
- » Environment protective hot air recycling device can save energy up to 40% , without hot air or dust discharging.
- » A closed loop material loading system to prevent the dried material from contacting with outside air so to avoid damping.
- » TDL integrate drying and single loading into one unit, adopts temp. Controller to accurately control temp.24-hour timer is available for choose.
- » Usual base and single tube suction box are Standard accessories.
- » Standard aluminum bases are equipped to all models in the series.
- » Hot air recycler, blower inlet filter, air filter, cyclone dust collector, magnetic base, hopper magnet, Euro suction box as your options.
- » Can match with TAL-900G to realize the two-stage loading function.



TDL-50+900G



TDL-50

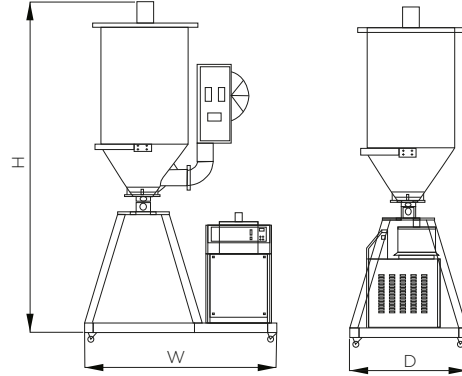

TECHNICAL FEATURES

Model	Applicable Dryer Model	Applicable Loader Model	Applicable Hopper Model	Transportation Capacity (kg/hour)	Hopper Volume	Dimensions (mm)	Weight
THL-25	THD-25	TAL-700G/800G	1xTVH-6L	300	6	1620x1000x640	95
		TAL-900G	1xTVH-6L 1xTMH-6L	450	2x6		
THL-50	THD-50	TAL-700G/800G	1xTVH-6L	300	6	1750x1000x640	110
		TAL-900G	1xTVH-6L 1xTMH-6L	450	2x6		
THL-75	THD-75	TAL-700G/800G	1xTVH-6L	300	6	1850x1000x640	115
		TAL-900G	1xTVH-6L 1xTMH-6L	450	2x6		
THL-100	THD-100	TAL-700G/800G	1xTVH-6L	300	6	1950x1080x710	155
		TAL-900G	1xTVH-6L 1xTMH-6L	450	2x6		
THL-150	THD-150	TAL-700G/800G	1xTVH-6L	300	6	2200x1080x710	160
		TAL-900G	1xTVH-6L 1xTMH-6L	450	2x6		
THL-200	THD-200	TAL-800G	1xTVH-6L	300	6	2385x1140x840	210
		TAL-900G	1xTVH-6L 1xTMH-6L	450	2x6		
THL-300	THD-300	TAL-800G	1xTVH-6L	300	6	2690x1140x840	285
		TAL-900G	1xTVH-6L 1xTMH-6L	450	2x6		
THL-400	THD-400	TAL-800G	1xTVH-6L	400	6	2800x1240x1020	285
		TAL-900G	1xTVH-6L 1xTMH-6L	700	2x6		

NOTE:

- » If equipped with Autotimer, add "T" to the model designation.
- » If equipped with magnetic aluminum base, add "M" to the model designation.
- » If equipped with double insulated layer, add "I" to the model designation.
- » If it is 180 high temp. model, add "H" to the back of the model.
- » If it has Euro safety regulation, add "CE" to the model designation.
- » If it has single phase voltage, add "S" to the model designation.

Euro Type Hopper Loader

THD-U

The THD-U series Euro hopper dryers adopt hot air down-blowing design and use stainless steel material hoppers to avoid contamination. With this design, they are also ideally suited for use with honeycomb dehumidifiers to dry engineering plastics. There are 25 models, available, ranging from 20U to 8000U liters with airtight material cleaning door on models, available material cleaning door on models THD-80U above. The microprocessor control featuring digital display and auto start/stop timer as Standard equipment.



THD-16U



THD-1500U



THD-80U

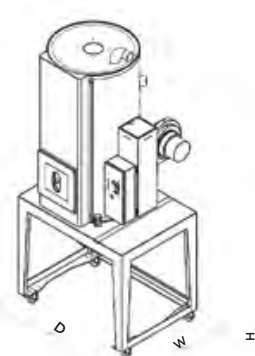

THD-20U-450U
With floor stand THD

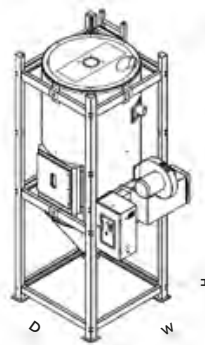

THD-600U-8000U

NOTE:

- » For polished hopper, add "P" to the model designation.
- » Blower is included in machine net weight, but floor stand is not included.

FEATURES:

- » Innovative design with sleek appearance.
- » Hot air down-blowing design ensures even distribution of hot air to maintain a steady temperature in the hopper and increase drying efficiency.
- » All material contact surfaces are made of stainless steel.
- » Material clearance door seal and makes clean down more convenient and effective. (models THD-80U and above)
- » Microprocessor is used for accurate temperature control.
- » Overheat protection to ensure reliable operation.
- » Digital P.I.D temperature control with LED display, 7 days automatic start/stop timer to improve energy saving.
- » Aluminum bases are equipped to model THD-20U to THD-1200U
- » Option accessories: magnetic base (aluminum or stainless steel), mobile flor stand, suction box, hot air recycling exhaust air filter, blower inlet filter.
- » Drying hopper and hopper lid can be fully insulated for high temperature application.

TECHNICAL FEATURES

Model	Heater Power	Blower	Hopper Capacity	Dimensions	Floor Stands	Overall Height	Air Inlet Pipe Diameter (inch)	Air Inlet Pipe Diameter (Inch)	Weight
THD-20U	2.4/3	0.12	20	730x575x325	790x450x550	1260	2"	2.5"	40
THD-40U	3/4.5	0.17	40	760x640x390	790x450x550	1295			45
THD-80U	4.5/6.6	0.17	80	940x722x475	840x552x722	1465	2.5"	3.5"	50
THD-120U	4.5/6.6	0.2	120	1210x722x475	840x552x722	1735			60
THD-160U	6.6/7.2	0.2	160	1225x822x575	920x662x795	1825	3"	4"	90
THD-230U	6.6/7.2	0.2	230	1505x822x575	920x652x795	2105			100
THD-300U	12/15	0.33	300	1450x945x695	970x790x930	2085			130
THD-450U	15/18	0.33	450	1850x945x695	970x790x930	2435			160
THD-600U	18/24	0.55	600	1820x1170x915	1130x1000x1200	2470	4"	5"	200
THD-750U	18/24	0.55	750	2100x1170x915	1130x1000x1200	2780			220
THD-900U	18/24	0.55	900	2070x1340x1050	1320x1200x1200	2730	4"	5"	250
THD-1200U	24/36	0.75	1200	2500x1340x1050	1320x1200x1200	3160			380
THD-1500U	36/48	1.1	1500	2950x1542x1250	1400x1500x1500	3470	5"	6"	495
THD-2000U	36/48	2.2	2000	3350x1542x1250	1400x1500x1500	3870			570
THD-2500U	48/60	3.7	2500	3510x1770x1400	1500x1640x1640	4050	5"	5"	620
THD-3000U	48/60	3.7	3000	3910x1770x1400	1500x1640x1640	4400			700
THD-3500U	60/72	5.5	3500	4310x1770x1400	1500x1640x1640	4800	8.6"	8.6"	785
THD-4000U	60/72	5.5	4000	4450x1980x1600	1650x1900x1900	4550			860
THD-4500U	84/96	5.5	4500	4350x1980x1600	1650x1900x1900	4850	8.6"	10.7"	940
THD-5000U	84/96	5.5	5000	4650x1980x1600	1650x1900x1900	5150			1050
THD-5500U	96/108	5.5	5500	4950x1980x1600	1650x1900x1900	5450			1120
THD-6000U	96/108	5.5	6000	4350x2220x1800	1650x2100x2100	5100	8.6"	12.8"	1210
THD-6500U	108/120	7.5	6500	4600x2220x1800	1850x2100x2100	5350			1285
THD-7000U	108/120	7.5	7000	4850x2220x1800	1850x2100x2100	5600			1375
THD-8000U	120/132	11	8000	5350x2220x1800	1850x2100x2100	5850			1445

Honeycomb Dehumidifier

TD-200

The TD-H series honeycomb dehumidifiers are mainly used to dry hygroscopic engineering plastics. A honeycomb-rotor is used in this series to offer effective drying. Under ideal conditions, honeycomb motor can supply dehumidified dry air with a dew-point down to-50C. The TD-H series offers accurate P.I.D. temperatures. This series comprise 14 models of honeycomb dehumidifiers, the largest of which can provide dry air up to a volume of 4000m³/hr.

FEATURES:

- » This series use P.I.D temperature control system, with regenerating temperature setting and real temperature display function.
- » Equips with dehumidifying heater and temperature control gauge as options to dry and dehumidify the raw material.
- » The dehumidifying system of the TD-H series features two condensers to ensure a low return air temperature and low dew-point.
- » Main power switch witch mechanical chain lock function



TD-200H



TECHNICAL FEATURES

CX									TB							
Model	TD-	30H	50H	80H	120H	150H	200H	300H	400H	500H	700H	1000H	1500H	2000H	3000H	4000H
Process Air Flow (m ³ / hour)		30	50	80	120	150	200	300	400	500	700	1000	1500	2000	3000	4000
Process Blower (kW)		0.2	0.4	0.85	0.85	1.6	1.6	3	4	2.2	2.2	5.5	11	11	11*2	11*2
Regeneration (kW)		0.2	0.4	0.4	0.4	0.85	0.85	0.85	0.85	1.6	1.6	3	3	4	3*2	4*2
Regeneration Blower (kW)		3	3	4	4	4	6	7	7	12	12	15	24	24	24*2	24*2
Outlet Pipe Diameter (Inch)		2"	2"	2"	2"	2.5"	2.5"	3	3	4	4	5"	5"	8.5"	8.5"	8.5-10.7"
Voltage Features		3 ϕ , 400V, 50Hz														
Dimensions																
Y(mm)		1260	1260	1360	1360	1560	1570	1745	1745	1935	1935	2145	2145	2060	2500	2500
Width (mm)		480	480	530	530	660	660	900	900	900	900	1300	1300	1410	1600	2000
D (mm)		755	755	820	820	1050	1050	1255	1255	1380	1380	1550	1910	2150	2160	2200
Weight		80	80	120	140	215	225	240	280	290	300	400	510	630	760	880

Process heater and temperature control are optional for this series.

SEPARATION	RELATIVE HUMIDITY	MOIST CONTENT	
		PPM	%
20	100	23.072	2.307
+10	52.50	12.117	1.212
0	26.10	6.027	0.603
-10	11.20	2.574	0.257
-20	4.40	1.025	0.103
-30	1.60	378	0.038
-40	0.60	128	0.013
-50	0.20	39	0.004

*ppm: 1/1.000.000

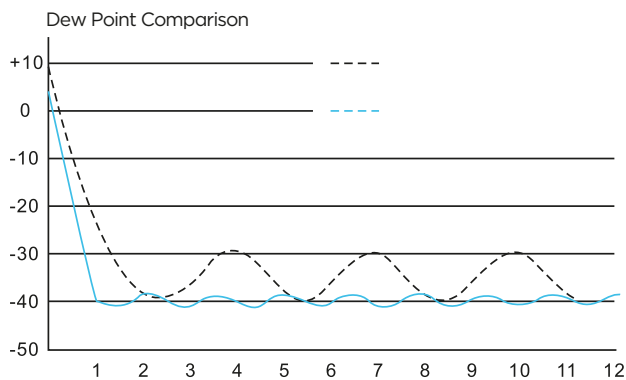

Outline Drawing

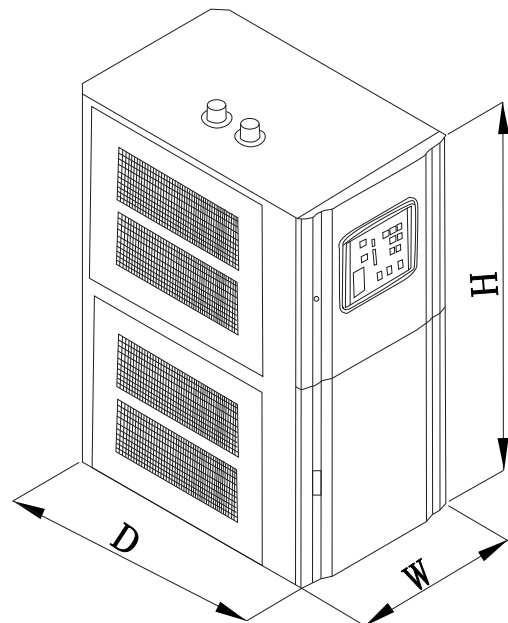

WHAT IS HONEYCOMB ?

The main part of honeycomb rotor is made by ceramic fiber and organic additives, sintered under high temperature with molecular sieve and silica gel as basic material to bond together with inside of honeycomb to form the honeycomb-like structure. Unlike common desiccant or rotary molecular sieve, which, when aging, will produce dust, followed by process air to drying hopper, to pollute plastic material. Honeycomb rotor offers unlimited long services life and can be cleaned. The moisture of return air is quickly absorbed by molecular sieves when passing through numerous holes within honeycomb rotor. So, when coming out of rotor it can form low dewpoint dry air.

The principles of regenerating and dehumidifying are similar and both of them carry out simultaneously. The only difference is that the two process winds are in opposite direction.

Working Principle

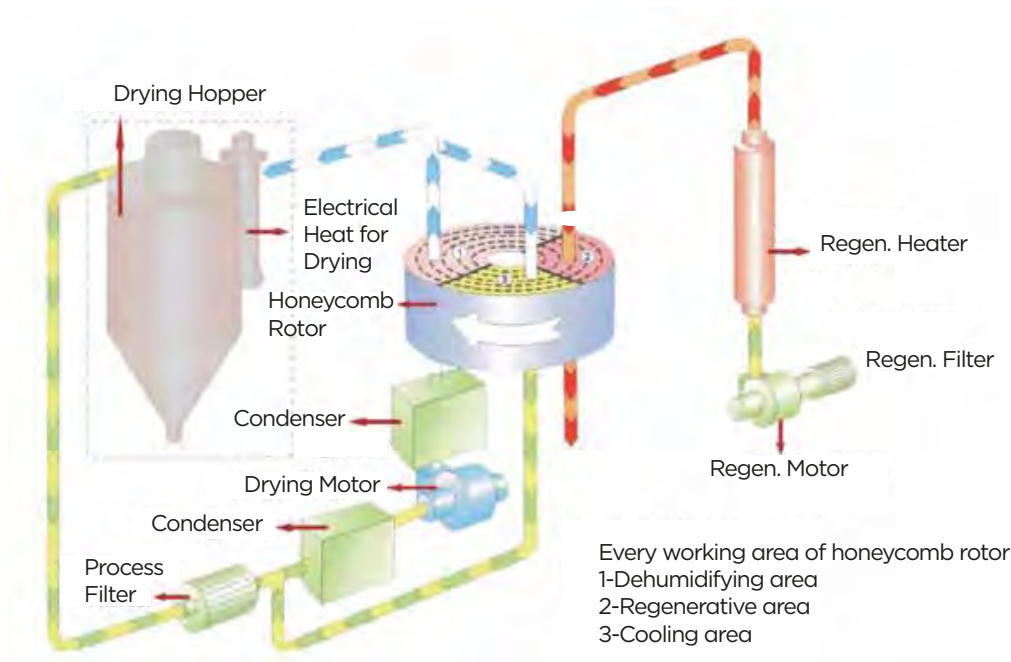

Internal Structure



Heat-resistant neoprene hose



Portable dew point meter



Integrated dew point control

NOTE:

- » Use separated drying hopper.
- » Moisture content lower than 0.005% after drying when in 20C atmosphere and 65% relative humidity.

Raw Material	Drying Heat	Drying Period (Hour)	Specific Heat	Weight Specific to the Material (kg / dm ³)	Moisture Content Prior to Drying (%)	Moisture Content Prior to Drying (%)	Drying Capacity (kg / hour)														
							TD-30H	50H	80H	120H	150H	200H	300H	400H	500H	700H	1000H	1500H	2000H	3000H	4000H
ABS	80	2-3	0.34	0.6	0.3	0.02	11	18	27	35	71	105	180	210	285	355	425	710	1065	1500	1600
CA	75	2-3	0.5	0.5	1	0.05	9	15	22	30	60	90	150	180	235	290	355	590	885	1200	1330
CAB	75	2-3	0.5	0.5	0.8	0.2	9	15	22	30	60	90	150	180	235	290	355	590	885	1200	1330
CP	75	2-3	0.6	0.6	1	0.02	11	18	27	35	71	106	180	210	235	355	425	710	1060	1500	1600
LCP	150	4	0.6	0.6	0.08	0.02	8	13	20	27	55	80	135	160	210	265	320	530	800	1150	1200
POM	100	2	0.35	0.6	0.2	0.02	16	27	40	53	105	160	265	320	425	530	640	1060	1600	1800	2400
PMMA	80	3	0.35	0.65	0.5	0.02	11	19	29	38	77	115	192	230	307	383	460	767	1150	1530	1730
IONOMER	90	3-4	0.55	0.5	0.1	0.04	7	11	17	22	44	66	111	133	177	220	265	442	663	750	1000
PA6/6.6/6.10	75	4-6	0.4	0.65	1	0.05	6	10	14	19	38	58	96	115	153	192	230	383	575	960	1040
PA11	75	4-5	0.58	0.65	1	0.05	7	12	17	23	46	69	115	138	184	230	275	460	690	780	1150
PA12	75	4-5	0.28	0.65	1	0.05	7	12	17	23	46	69	115	138	184	230	275	460	690	780	1150
PC	120	2-3	0.28	0.7	0.3	0.01	13	21	31	41	83	124	206	250	330	413	495	826	1238	1400	1860
PU	90	2-3	0.45	0.65	0.3	0.02	11	19	29	38	77	115	190	230	307	383	460	767	1150	1530	2080
PBT	130	3-4	0.3-0.5	0.7	0.2	0.02	9	15	23	31	62	93	155	186	248	310	372	620	930	1100	1600
PE	90	1	0.55	0.6	0.01	0.01	32	53	80	106	212	318	531	637	850	1062	1275	2125	3185	3600	4800
PEI	150	3-4	0.6	0.6	0.25	0.02	8	13	20	27	53	80	133	160	212	265	320	530	800	1030	1370
PET	160	4-6	0.3-0.5	0.85	0.2	0.05	8	13	19	25	50	75	125	150	200	250	300	500	750	1150	1360
PETG	70	3-4	0.6	0.6	0.5	0.02	8	13	20	27	53	80	133	160	212	265	320	530	800	1030	1370
PEN	170	5	0.85	0.85	0.1	0.05	9	15	23	30	60	90	150	180	240	300	360	600	900	1150	1360
PES	150	4	0.7	0.7	0.8	0.02	9	15	23	30	60	90	150	180	240	300	360	600	900	1050	1400
PMMA	80	3	0.65	0.65	0.5	0.02	11	19	29	38	77	115	190	230	310	385	460	765	1150	1530	1730
PPO	110	1-2	0.4	0.5	0.1	0.04	13	22	33	44	88	133	220	265	355	440	530	885	1330	1730	2660
PPS	150	3-4	0.6	0.6	0.1	0.02	8	13	20	27	53	80	133	160	212	265	320	530	800	1030	1370
PI	120	2	0.27	0.6	0.4	0.02	16	27	40	53	105	160	265	320	425	530	640	1060	1600	1800	2400
PP	90	1	0.46	0.5	0.1	0.02	26	44	66	88	180	265	442	530	710	885	1060	1770	2655	3500	4000
PS(GP)	80	1	0.28	0.5	0.1	0.02	26	44	66	88	180	265	442	531	708	885	1062	1770	2655	3500	4000
PSU	120	3-4	0.31	0.65	0.3	0.02	8	14	22	29	60	85	145	173	230	290	345	575	865	1300	1485
PVC	70	1-2	0.2	0.5	0.1	0.02	13	22	33	44	90	135	220	265	355	442	530	885	1330	1730	2660
PAN(AS)	80	1-2	0.32	0.5	0.1	0.05	13	22	33	44	90	135	220	265	355	442	530	885	1330	1730	2660
TPE	110	3	0.7	0.7	0.1	0.02	13	20	30	40	85	125	205	250	330	413	495	826	1238	1650	1860

2 in 1 Dehumidifiers

TDD

The TDD series dehumidifying dryer combine dehumidifying and drying system in a single unit. They have many applications in processing plastic materials such as PA, PC, PBT, PET, etc. We offer two types of honeycomb rotors: H4 and H5 models, which under ideal conditions, can supply dehumidified dry air with a dewpoint down to -50 and -50 respectively. All models featured with TD-H honeycomb dehumidifiers with built-in process heater and insulated drying hopper. The TDD series offers accurate PID temperature control as Standard, with LCD touch screen, dew-point monitor and hopper loaders.

FEATURES:

- » The TDD dehumidifying dryer use honeycomb dehumidifiers with an eye catching semi-integral appearance.
- » Each model combines dehumidifying and drying functions into a single unit.
- » Material processing is controlled via microprocessor as Standard with touch screen PLC control as an option for more convenient control.
- » Insulated drying hopper features dry air downflowing and cyclone exhaust design. This improves drying efficiency and reduces energy consumption whilst maintaining a steady drying effect.
- » Compact in size for ease of movement and space saving.
- » The dehumidifying section of the TDD series features two condensers to ensure a low return air temperature and low-dewpoint.
- » Dew-point monitor can be fitted to check dry air dewpoint.
- » Optional suction box and hopper loader for conveying material conveniently.



Integrated dew point control



TDD-300U/200H

TECHNICAL FEATURES

	Regenerative Heater Power)	Regenerative Fan Power	Process Heater Power	Process Fan Power	Dry Air Capacity	Drying Chamber Capacity	Dimensions	Weight
Model	3	0.2	2.4/3	0.2	30	20	1240x875x755	110
TDD-20U/30H	3	0.2	3/4.5	0.4	30	40	1300x930x755	190
TDD-40U/30H	3	0.4	3/4.5	0.4	50	40	1300x930x755	190
TDD-40U/50H	3	0.4	4.5/6.6	0.4	50	80	1410x1030x755	210
TDD-80U/50H	4	0.4	4.5/6.6	0.85	80	120	1780x1220x820	250
TDD-120U/80H	4	0.4	6.6/7.2	0.85	80	160	1740x1220x820	255
TDD-160U/80H	4	0.4	6.6/7.2	0.85	120	160	1740x1220x820	265
TDD-160U/120H	4	0.4	6.6/7.2	0.85	120	230	2010x1220x820	295
TDD-230U/120H	4	0.4	6.6/7.2	1.6	150	230	2150x1450x1050	375
TDD-230U/150H	4	0.4	12/15	1.6	150	300	2040x1450x1050	410
TDD-300U/150H	6	0.4	12/15	1.6	200	300	2040x1450x1050	420
TDD-300U/200H	6	0.4	15/18	1.6	200	450	2440x1450x1050	550
TDD-450U/200H	7	0.85	15/15	3	300	450	2480x1490x1255	580
TDD-450U/300H	7	0.85	18/24	3	300	600	2380x1745x1255	615
TDD-600U/300H	7	0.85	18/24	4	400	600	2380x1745x1255	620
TDD-600U/400H	7	0.85	18/24	4	400	750	2610x1745x1255	650
TDD-750U/400H	12	1.6	18/24	2.2	500	750	2760x2140x1380	760
TDD-750U/500H	12	1.6	18/24	2.2	500	900	2640x2140x1380	820
TDD-900U/500H	12	1.6	18/24	2.2	700	900	2640x2140x1380	830
TDD-900U/700H	12	1.6	24/36	2.2	700	1200	3070x2140x1380	870
TDD-1500U/1000H	15	3	36/48	5.5	1000	1500	3300x13600x2500	1200
TDD-2000U/1000H	15	3	36/48	5.5	1000	2000	3500x3600x2500	1500
TDD-2500U/1500H	24	4	48/60	11	1500	2500	3500x3600x2500	2000
TDD-4000U/2000H	24	4	72/84	11	2000	4000	4500x3900x2700	2800

NOTE:

- » Polished treatment on all material contact surfaces, add "P" to the model designation.
- » Modified into "180C and heat-preservation" add "HT" to the model designation.
- » LCD touch screen, PLC controller, add "LC" to the model designation.

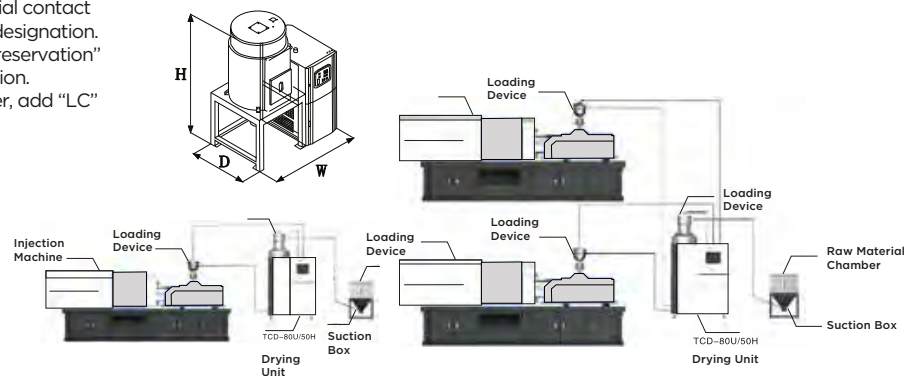

3 in 1 Compact Dryers

TCD

TCD series combining 2-stage feeding, dehumidifying, and drying into one unit, is widely used in all kinds of plastic raw materials, especially the hygroscopicity strong engineering plastics, such as PA, PC, PBT, PET. TCD-H in the ideal state can reach the lowest dew point of -50°C. This series use TD-H honeycomb dehumidifier and stainless steel materials barrel with down-blowing type. All series adopt P.I.D temperature control system for the Standard equipment, and PLC control with LCD touch human-machine interface for selection. Dew point meter and automatic loading machine is optional.

FEATURES:

- » TCD series compact dryers are equipped with honeycomb rotor for dehumidifying. They have two kinds of design: Fully-integral and semi-integral depending on the size.
- » Suitable for drying hygroscopic engineering plastics such as PA, PC, PBT, PET, etc. Integration of dehumidifying, drying, and two-stage conveying functions in a single unit.
- » Three-stage conveying is also available as an option
- » Insulated drying hopper features dry air down-blowing and cyclone exhaust design. This improves drying efficiency and reduces energy consumption which maintaining a steady drying effect.
- » Closed loop conveying system eliminates the possibility of moisture re-absorption during material conveying.
- » The dehumidifying section of TCD series features two condensers to ensure a low return air temperature and low dewpoint.
- » Equipped with pneumatic shut-off valve to ensure no material remains in the material line after each loading cycle.
- » Material processing is controlled via microprocessor as Standard with touch screen PLC control as an option for centralized and automatic operation.
- » Dew-point monitor can be fitted to monitor and display dry air dewpoint.



TCD-80U/50H

TECHNICAL FEATURES

Model	TCD-	20U/30H	40U/30H	40U/50H	80U/50H	120U/80H	160U/80H	160U/120H	230U/120HU	230U/150H	300U/150H	300U/200H	450U/200H
Process Heater Power		3	3	4	4	6	6	6	7	7	12	12	15
Process Fan Power		0.2	0.4	0.4	0.4	0.85	0.85	0.85	0.85	1.6	1.6	1.6	1.6
Drying Chamber Capacity		20	40	40	80	120	160	160	230	230	300	300	450
Dehumidification System													
Regenerative Heater Power		3	3	3	3	4	4	4	4	4	4	6	6
Regenerative Fan Power		0.2	0.2	0.4	0.4	0.4	0.4	0.4	0.4	0.4	0.4	0.4	0.4
Drying Air Capacity		30	50	50	50	80	80	120	120	150	150	200	200
Transportation System													
Transportation Blowing Power		0.85	0.85	0.85	1.6	1.6	1.6	1.6	1.6	1.6	1.6	1.6	1.6
Transportation Hose Diameter (Inch)		1.5	1.5	1.5	1.5	1.5	1.5	1.5	1.5	1.5	1.5	1.5	1.5
THR-U-E Chamber Receiver (L)		3	3	3	6	6	6	6	12	12	12	12	12
THR-U Chamber Receiver (L)		3	3	3	6	6	6	6	12	12	12	12	12
Dimensions													
Y (mm)		1490	1550	1550	1520	1990	1860	1860	2070	2130	2160	2160	2350
G (mm)		1000	1040	1040	950	1105	1190	1190	1190	1425	1460	1460	1460
D (mm)		875	875	875	810	875	875	875	875	1015	1020	1020	1020
Weight		305	325	335	325	340	385	505	515	540	560	565	595

Model	TCD-	450U/300H	600U/300H	600U/300H	750U/400H	750U/500H	900U/500H	900U/700H	1200U/700H
Process Heater Power		15	18	18	18	18	24	24	24
Process Fan Power		3	4	4	4	5.5	5.5	5.5	5.5
Drying Chamber Capacity		450	600	600	750	750	900	900	1200
Dehumidification System									
Regenerative Heater Power		7	7	7	7	12	12	12	12
Regenerative Fan Power		0.85	0.85	0.85	0.85	1.6	1.6	1.6	1.6
Drying Air Capacity (m ³ /hour)		300	300	400	400	500	500	700	700
Transportation System									
Transportation Blowing Power		1.5	1.5	1.5	1.5	1.5	2.4	2.4	2.4
Transportation Hose Diameter (Inch)		1.6	1.6	1.6	1.6	1.6	2	2	2
THR-U-E Chamber Receiver (L)		12	12	12	12	12	24	24	24
THR-U Chamber Receiver (L)		12	12	12	12	12	24	24	24
Dimensions									
Y (mm)		2480	2480	2380	2610	2760	2640	2640	3070
G (mm)		1490	1745	1745	1745	2140	2140	2140	2140
D (mm)		1255	1255	1255	1255	1380	1380	1380	1380
Weight		600	635	640	690	710	820	850	900

NOTE:

- » Full-integram design is optional for models ranging from TCD-450U/300H to TCD-750U/500H
- » Power supply: 3 Φ , 400V, 50Hz

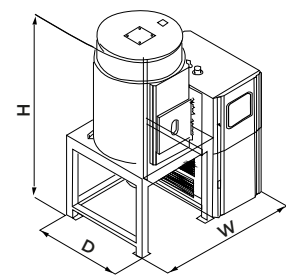
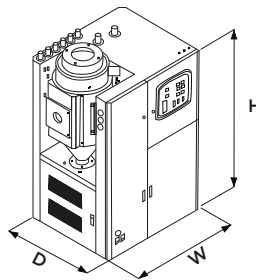

**GRANULATORS AND
RECYCLING**



Screenless Granulators

TG-2627

TG-2618/27/36 series granulators operate in super low speed to cut materials into well proportioned granules. There are least dusts produced in the cutting process. Multiple security devices ensure high safety grade; granulating hard and This series of screenless granulators are suitable for thick materials.



TG-2627

FEATURES:

- » Gear motor features steady steady performance long service life and high torque.
- » Teeth cutters and cutting blades are integrally fitted in one cutting chamber.
- » "Euro" style appearance,compact in size and easy to access for cleaning and maintenance.
- » Transparent PC feeding hopper.
- » Screenless design, well-proportioned size of regrinds and least amount of dusts.Regrinds could be used with virgin materials.



Model	TG-2618	TG-2627	TG-2636	TG-2050
Motor Power	0.75	0.75(1.5)	1.5(2.2)	2.2(3.7)
Rotor Speed	24.2	24.2	24.2	28.8
Blade Material	SKD11	SKD11	SKD11	SKD11
Number of Fixed Blades	2	3	4	
Number of Moving Blades	1	2	3	
Feeding Input (mm)	180x271	271x271	361x271	400*450
Maximum Capacity (kg/hour)	3	6.5-7	9-10	20-25
Sound Level	65-73	65-73	65-73	65-73
Instant Recycling	○	○	○	
Crushing Conveyor	○	○	○	
Dust Separator	○	○	○	
Manual Storage Chamber	○	○	○	
Dimensions				
A (mm)	326	415	506	450
B (mm)	416	490	416	520
C (mm)	610	500	610	1450
D (mm)	387	545	567	550
H (mm)	1250	1245	1250	1300
Weight	220	250	310	512

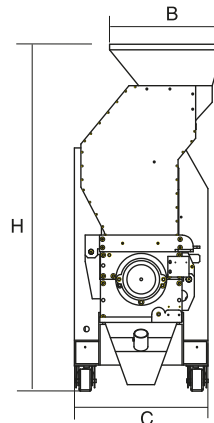
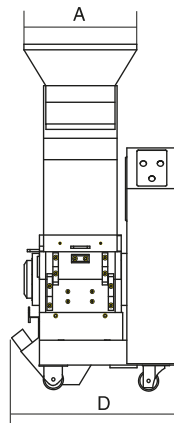

Low Speed Granulators

TG-1828

TG-series low-speed granulators are suitable for by-the-press recycling of sprues. They feature easy operation, excellent performance, low noise and dust level. They are in "Euro" style design and compact in size. High quality blades ensure long-life span. High security grade also conforms with CE safety standard.



TG-1828

FEATURES:

- » High safety design.
- » Small in size with castors for easy moving.
- » Best shear angle ensure the efficiency of material granulating.
- » Low speed and sound prof material hopper brings a quieter operation environment.
- » Staggered blades can increase working efficiency and at the same time reduce energy consumption.
- » Well-propo ioned granules and low dust level.
- » Easy to Access for easy maintenance and cleaning.
- » Low granulating speed and sharp angle design of rotating blades are helpful for smooth and continuous operation.
- » For granulating fiber-added material, cutting-chamber can be optionally made in HT300 material.

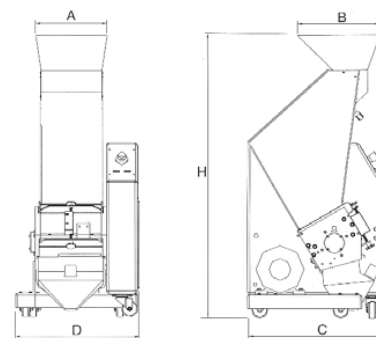

TECHNICAL FEATURES

Model	TG-1814	TG-1821(H)	TG-1828(S)	TG-1835(H)	TGT-1842(H)
Motor Power	1.5	1.5/2.2	2.2/1.5	2.2/3	2.2/3/4
Rotor Speed	190	190	190	190	190
Fixed Blades	2X1	2X1	2X1	4X1	4X1
Rotary Blades	3X2	3X3	3X4	3X5	3X6
Crushing Chamber	180X140	180X210	180X280	180X350	180X420
Maximum Production Capacity (kg/hour)	20	35/40	70/60	85	100
Sound Level	76	81	82	82	85
Blade Material "SKD11"	✓	✓	✓		
Diameter of Sieve Hole (5mm)	✓	✓	✓		
Diameter of Sieve Hole (4,6,8,10,12mm)	○	○	○		
Instant Recycling	○	○	○		
Proportioner Valve	○	○	○		
Fan Transport (with cyclone)	○	○	○		
Venturi Loader VR	○	○	○		
Dust Separator (with instant recycling)	○	○	○		
Level Sensor	○	○	○		
Dimensions					
A (mm)	260	390	435	495	560
B (mm)	380	420	420	425	420
C (mm)	600	680	685	680	680
D (mm)	405	470	570	620	620
H (mm)	1300	1330	1300	1310	1310
Weight	175	175	190(180)	200	

Powerful Granulators

TGP-500

TG series of granulators include claw cutter series, flat cutter series and blade cutter series. They are applicable to a wide range, can meet a wide variety of requirements, able to granulate & recycle all kinds of plastics material of different texture and shapes.



TGP-500

CLAW CUTTER SERIES:

Suitable for recycle and restore of all kinds of plastics, e.g. blow molded products and shoelast. TG claw series are easy to operate and simple to replace cutter blades, well designed cutter base, cutter blades are able to disperse bearing force & increase the power effectively of each cutter & reduces wear and tear, fully installed with electrical safety devices. Double wall hopper designed installed with soundproof material for safety and environment. Low electricity consumption and durable build.



Claw cutter saddle

FLAT CUTTER SERIES

Suitable for recycle of plastic casing, thin tube plastics, sprues from injection moulding sector, bottle plastics and shell plastics. TG series are easy to operate and simple to replace cutters. Spacious flat blade is suitable to granule bulky & thin plastics, increases efficiency; comes with electrical safety devices installed. Double wall hopper designed installed with soundproof material for safety and environment. Low electricity consumption and durable build.



Flat cutter saddle

BLADE CUTTER SERIES

Blade cutter is in between claw and flat cutter blade. Suitable for recycle and restore of conventional sheets, tube plastic, profiles, packing plastics, extrusion mould products & runners. General operation is adopted with airtight sealed bearing to allow long hours rotation; well designed cutter blades, to ensure the balance of pellets sizes after being crushed; cutter base with special heat treatments.



Blade cutter saddle



Flat cutter saddle

TGY Features

Model	TGY250	TGY380	TGY480	TGY500	TGY630	TGY700	TGY790	TGY960	TGY1100
Feeding Input	250x200	380x240	480x290	540x330	630x340	700x480	6790x550	960x610	1100x800
Crushing Capacity (kg/hour)	100-200	200-300	300-500	300-400	400-500	450-600	600-800	700-900	900-1100
Fixed Blade	2	2	2	2	4	2	4	4	4
Rotary Blades	12	18	21	21	27	27	27	30	45
Power	kW	4	7.5	11	15	22	22/30	37/45	75
	HP	5	10	15	20	30	30/40	50/60	100
Dimensions	900x660x1200	1010x810x1390	1200x960x1670	1300x1010x1810	1400x1200x1800	1700x1430x2350	1900x1630x2670	1900x1760x2780	2550x2050x3440
Net Weight	290	516	850	900	1400	1800	3000	3000	6000
Diameter of Sieve Hole	Ø7	Ø10	Ø12	Ø12	Ø12	Ø12	Ø12	Ø12	Ø12

TGD Features

Model	TGD380	TGD500	TGD800	TGD815	TGD960	TGD1100
Feeding Input	380x240	504x330	815x470	815x520	960x610	1100x800
Crushing Capacity (kg/hour)	200-300	300-400	850-600	550x700	600-800	800-1000
Fixed Blade	2	2	4	4	4	4
Rotary Blades	6	6	9	12	12	12
Power	kW	7.5	15	22/30	37	75
	HP	10	20	30/40	50	100
Dimensions	1010x810x1670	1300x1010x1810	1700x1500x2400	1720x1540x2450	1900x1760x2780	2550x2050x3440
Net Weight	515	900	2000	2300	3000	3000
Diameter of Sieve Hole	Ø10	Ø12	Ø12	Ø12	Ø12	Ø12

TGP Features

Model	TGP230	TGP300	TGP400	TGP500	TGP600	TGP700	TGP800
Feeding Input	230x200	310x210	410x240	515x300	610x330	715x330	815x470
Crushing Capacity (kg/hour)	100-150	150-200	200x250	300x350	350x450	400-500	450x600
Fixed Blade	2	2	2	2	4	4	4
Movable Blade	6	9	12	15	18	21	24
Power	kW	4	5.5	7.5	11	15	22/30
	HP	5	7.5	10	15	20	20/40
Dimensions	950x640x1220	1000x730x1320	1020x830x1390	1200x1000x1670	1300x1100x1800	1400x1200x1800	1700x1500x2400
Net Weight	288	432	500	900	1100	1500	2000
Diameter of Sieve Hole	Ø7	Ø10	Ø10	Ø12	Ø12	Ø12	Ø12

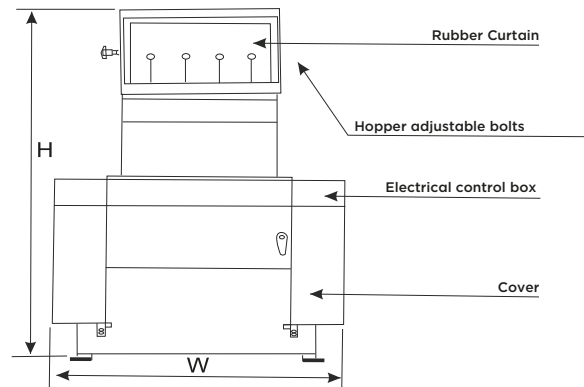
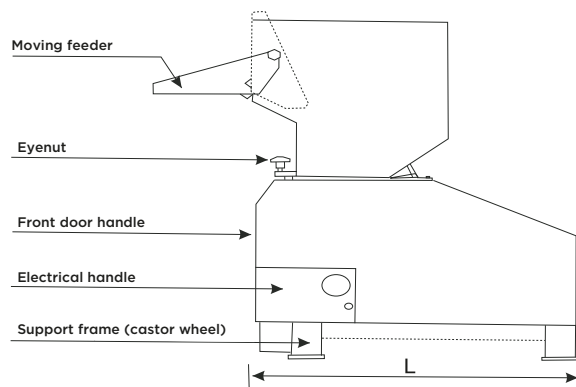

Soundproof Granulators

TG-36

TG-26/36/40 series is suitable for granulating a variety of plastic materials, including waste materials of injection molding, blowing molding and extrusion molding. This series is compacted in structure, easily operating, conveniently reblading and powerful granulating ability. Gradual cutting integrated design ensures better cutting efficiency and low level noise.



TG-36

FEATURES:

- » Roasting blade adopts the latest 'v' cutting technology. Plastics materials will be conveyed to the center of roasting cutter ensuring no materials pasting up on the side wall and prolong its life.
- » Cutter is made of imported high quality material, with high hardness, long life and wear-resisting ability. It is grinding and reusable.
- » Cutter base is optimal. Simple and convenient blade installation technology ensures roasting blade and fixed blade adjustable in the clamp.
- » Granulating chamber of high hardness, processed by numerical control machine, has the following features: big thickness, high strength, wear-resisting ability, no contamination, long life and easy maintainance.
- » Precise design, totally enclosed sound-proofing box with low level noise.
- » Totally sound-proof charging box enables the granulator running with low level noise. With the material fender, plastic materials will not splash out when granulating.
- » Balanced running, precise corporation, convenient Access and easy maintainance.
- » Charging box is uncovered by electric putter, with self-locking function, easy operation.
- » Dust separator is for option. Height of floor stand is adjustable in a range.
- » Cooling water clip is helpful to efficiently reduce granulate chamber's temperature.
- » Additional fixed blades could be used to enhance its granulating ability against massiness materials.
- » Against the material with fibre, granulating chamber and other related parts shall be surface hardening treated.
- » Upon request, it can be built to comply with worldwide electrical safety Standard (for example: CE)

Model	Motor Power (kW)	Feeding Input Size	Screen Diameter	Maximum Breaking Capacity (kg/hour)	Rotary Blades		Fixed Blades	Weight	Dimensions	
					Rotary Blades	Number of Stepped Blades				
TG-26	40 (H)	7.5 (11)	260x400	Φ 10	300-550	6	24	2	450	1250x910x1387
	50 (H)	11 (15)	260x500	Φ 10	400-650	6	30	2	650	1250x1010x1387
	60 (H)	11 (15)	260x600	Φ 10	270-350	3	18	2	900	1250x810x1387
TG-36	60 (H)	15	360x600	Φ 12	400-700	6	30	4	1000	1425x1156x1850
	70 (H)	18.5	360x700	Φ 12	500-800	6	36	4	1500	1425x1256x1850
	80 (H)	22	360x800	Φ 12	600-900	6	42	4	1750	1515x1356x1970
TG-40	60 (H)	15 (18.5)	400x600	Φ 12	400-600	6	18	4	1070	2080x1480x2160
	70 (H)	18.5 (22)	400x800	Φ 12	600-800	6	21	4	1180	2280x1680x2360
	80 (H)	22 (30)	400x1000	Φ 12	800-1000	6	24	4	1390	2480x1880x2560
	100 (H)	30 (37)	400x700	Φ 12	Φ 400-700	6	30	4	1590	

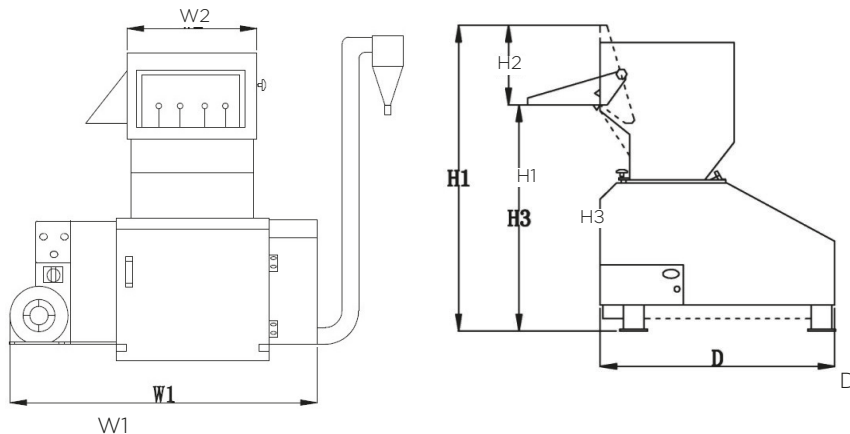

CT SHREDDER



FEATURES:

- » CTX series shredding and crushing machine combined in one-piece unit. It brings input materials such as discharge and bulky objects to the desired granule size in two stages.
- » From wedges, 40mm pieces to 10mm recycled material, proven size reduction technology produces even and smooth recycled material that is ready for immediate reuse.
- » Without a conveyor between the shredder and the crusher, the compact design saves up to 65% space for your factory.
- » The integrated crusher and grinder with intelligent control enable energy saving and continuous operation.
- » Plastic wedges, flushes, and defective materials.
- » Zyclone Collection.
- » Fast material collection, dust-free collection by reducing labor. Easy material recovery with no dust and less labor.
- » Conveyor Feeding.
- » With continuous material feeding, it works in accordance with the shredder/crusher workload.
- » Metal Separation
- » It prevents foreign objects from reaching consecutive machines.
- » Individual shredder; Compared with granulator and conveyor, space-saving is maximized, and investment is minimized.
- » One-step size reduction to desired final output size.
- » The pusher with curve ensures continuous operation and eliminates residual material
- » The automatic reverse system redirects the shredder rotors in the event of motor overload and material jams.
- » Shredder rotor blades are made of DC53 and crusher blades are made of Cr12Mov
- » Shredder and crusher are driven separately for better control.
- » Main electrical components and trusted brands such as Siemens and Schneider

CTX



Solid, Stable and Combative Jumbos

FEATURES:FEATURES:

- » Working principle
- » The working principle of the shredder blade: In the daily operation, the shredder can put the material into the chassis through the feeding system, and the motor drives the power system to make the shredder blade move and fixed knife to cut. The action of squeezing and shredding is repeated to complete the shredding of the material, and then the shredded material is discharged through the screen, so that the operation of shredding the material is completed.
- » Scope of application
- » The main crushed materials of the uniaxial plastic shredder: plastic, head material, plastic head material, nozzle material, plastic block, plastic film, agricultural film, plastic film, PP woven bag, ton bag, ton bag, stretch film greenhouse film, pipes, PE bottles, daily miscellaneous plastic bottles, plastic tables and stools, foam, etc.
- » Product Introduction
- » Function introduction of single shaft plastic shredder: P series single-shaft shredder is a small, high-performance, high-efficiency, and high-output shredding equipment suitable for shredding plastic materials. It is suitable for shredding plastic products, pipes, plastic heads, nozzle materials, machine head materials, etc. with high toughness and high hardness. The single-shaft shredder P series machine is equipped with push material setting and PLC automatic control system to realize intelligence. According to the type of crushed plastic material, the output of this series of P260 single-shaft plastic shredders is about 300kg/hour to 2000kg/hour.

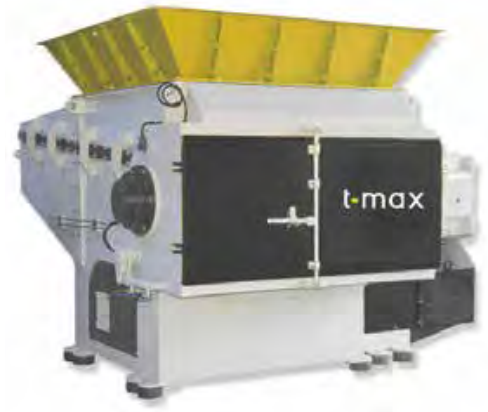

Model	T4150	T4200	T6170	T6220	T8180	T8240
Crushing Chamber AxB	1400x1500	1400x1500	1500x1600	1500x2200	1580x1800	1580x2200
Maximum Production Capacity (KG/H)	3000	4000	4700	5800	6500	8500
Rotor Diameter (mm)	450	450	600	600	800	800
Rotary Blades (PCS)	88	118	94	130	106	142
Number of Fixed Blades (PCS)	6	8	6	8	8	8
Motor Power (KW)	90	55+55	132	90+90	90+90	132+132
Hydraulic Motor Power (KW)	7.5	7.5	11	15	11	15
Dimensions UxGxY (mm)	3500x3100x2400	3500x4500x2400	3800x3200x2800	3800x4700x2800	4200x4300x3400	4200x4900x3400
Overall Machine Weight (KG)	11000	14.800	13.800	18000	16000	20000

*Maximum production capacity is the rubber head that is not ABS with screen diameter of 40 mm.

Small single shaft shredder

Working principle

- » Plastic shredder (single shaft) is mainly composed of spindle, blade, fixed knife, box feeding system, pushing system, power system, etc.
- » It uses the interaction between the moving knife and the fixed knife, and controls the discharge size through the screen, and shreds, cuts, and extrudes the material to a smaller size.
- » It is often used for primary crushing of various plastic solid wastes, and can process materials to smaller sizes at one time.
- » It has the characteristics of controllable discharge particle size, wide material applicability and high efficiency.



Small, Single Shaft Shredder

Scope of application

- » The main crushed materials of the uniaxial plastic shredder: plastic, head material, plastic head material, nozzle material, plastic block, plastic, film agricultural film, plastic film, PP woven bag, ton bag, ton bag, stretch film greenhouse film, pipes, PE bottles, daily miscellaneous plastic bottles, plastic tables and stools, foam, etc.

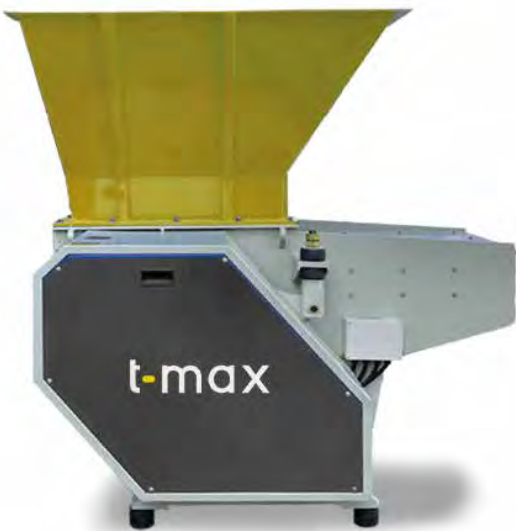

Product Introduction

- » P series single-shaft shredder is a small, high-performance, high-efficiency and high-output shredding equipment suitable for shredding plastic materials. It is suitable for shredding plastic products, pipes, plastic heads nozzle materials, machine head materials, etc. with high toughness and high hardness. The single-shaft shredder P series machine is equipped with push material setting and PLC automatic control system to realize intelligence.



Scope of Application:



Leather-Fabric



Back rest



Pet Plastic Bottle



Big Bag Breaking



Wood

Main Components:



Characteristics of the Equipment

- » The moving knife is made of DC53 material, and the fixed knife is made of D2 material
- » For hollow and large-volume materials, a pressing device can be selected.
- » Automatic overload protection function to avoid serious overload and jam of the machine. International brands such as Siemens and Schneider
- » The split-type combination technology is adopted, which can quickly and effectively replace the blade.
- » The movable knife can be replaced and the cutting edge needs to be replaced after 2 times, which reduces the operating cost.
- » The screen mesh is highly interchangeable and can be replaced
- » The guide bars and guide blocks in the push box can be replaced and adjusted to maintain smooth pushing and the sealing of the crushing chamber.



Model	P260	P380	P3120	P3150
Feeding Size A*B (MM)	500*580	850*800	850*1200	850*1400
Maximum Production Capacity (kg/hour)	500	1200	2000	2200
Rotor Diameter (MM)	250	400	400	400
Rotary Blades (pcs)	26	38	58	82
Fixed Blades (pcs)	4	4	4	4
Screen aperture (MM)	40	40	40	40
Motor Power (KW)	18.5	37	55	75
Hydraulic Motor Power (KW)	1.5	3.7	5.5	5.5
Dimensions (L*W*H MM)	1760*1300*1850	2850*1760*2210	2850*2560*2330	2850*2760*2330
Overall weight (KG)	1750	4150	5300	5900

Remarks: The maximum production capacity is the calculation of non-ABS plastic head with 40mm screen diameter



MOBILE MIXERS

Ideal for batch mixing the ergonomic design of the CM Mixer, which is mounted on telescopic is ideal within the plastic processing industry. Material is handled in an easy and efficient manner. Furthermore, the cover can be easily removed making it ideal and comfortable for cleaning purposes.

The design allows the vacuum of the material to be loaded through an external hopper loader - ideal for material handling!



Mixer with Screen

Model	TX-SM 70 Cr	TX-SM 120 Cr	TX-SM 200 Cr	TX-SM 300 Cr
L (mm)	600x600	700x700	800x800	900x900
H (mm)	900/1100	1050/1235	1200/1600	1200/1600
Capacity	70kg	120kg	200kg	300kg

Mixers complete with:

electric control panel: for continuous rotation or pause - run.

It is excellent for mixing the material; it replace the old drums. It is equipped with a practical system which sucks the material to be transferred to the machine tool. Side machine mixers with electrical box (continuous rotation or with timer) and security switches installs on the charging door and on the discharging door placed on the lower part of the mixer.

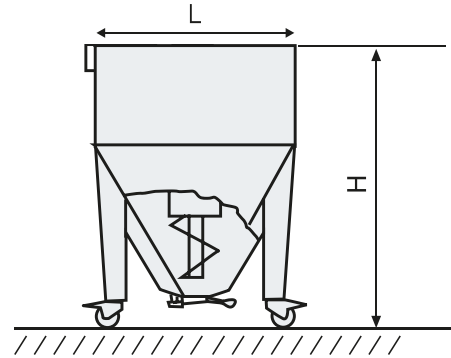

Mixer with touch screen control



Safety switch



Name plate



Flange for hopper loader

VERTICAL MIXERS



Vertical Mixer for granules and rigid flakes mixing, available in different sizes and capacities. Realized in painted steel and stainless steel AISI 304. In option unloading cells, top unloading pipe to fill the big-bag, forced load to a faster big-bag emptying, timer pause/work on the electrical panel. On request, versions with a capacity up to 50.000 liters. Available version on wheels up to 2.450 liters.

FEATURES:

- » Ideal for mixing of grains and ground products.
- » Wide range of models with volumes from 300 to 16,000 litres.
- » Reliability and Safety for the operators.
- » Product loading with incorporated hopper.
- » Large hatches for easy inspection and cleaning.
- » In-hopper unloading for mixing control.
- » Application of special outlet for connection to flexible or pneumatic mechanical conveyors
- » Stainless steel and specially constructed versions available on request.
- » Available in versions from 180 to 500 litres.
- » Fitted with wheels: can be used on several machines and positioned even where space is limited.
- » Can be connected to flexible and pneumatic conveyors.
- » The MM2.ED series is equipped with an incorporated, automatically controlled heater to provide hot air.

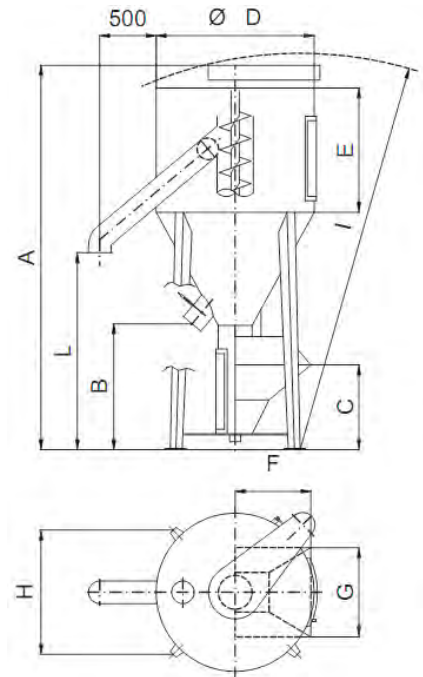

Model	Capacity (kg)*	A	B	C	D	E	F	G	H	I	L	kW	Weight
TX-VM 500	300 kg	2590	1165	670	1000	650	600	650	1010	2700	-	1,5	250 kg
TX-VM 1000	600 kg	2950	1165	670	1000	1000	600	650	1010	3040	-	2,2	330 kg
TX-VM 1800	1000 kg	3350	1175	700	1400	1100	650	750	1280	3462	-	4,0	450 kg
TX-VM 2500	1500 kg	3765	1180	800	1700	1250	750	900	1510	3933	-	5,5	580 kg
TX-VM 3500	2000 kg	4015	1180	800	1700	1500	750	900	1510	4175	1800	7,5	780 kg
TX-VM 5000	3000 kg	4515	1180	800	1700	2000	750	900	1510	4656	1800	9,0	940 kg
TX-VM 8000	5000 kg	4975	1180	800	2200	2000	750	900	1860	5141	1800	11,0	1250 kg
TX-VM 10000	6000 kg	5470	1180	800	2200	2500	750	900	1860	5626	1800	11,0	1380 kg
TX-VM 12000	7200 kg	5970	1180	800	2200	3000	750	900	1860	6105	1800	15,0	1500 kg
TX-VM 15000	9000 kg	6115	1160	800	2500	3000	750	900	2090	6280	1800	15,0	1650 kg
TX-VM 16500	10.000 kg	6415	1160	800	2500	3300	750	900	2090	6575	1800	15,0	1700 kg
TX-VM 20000	12.000 kg	7200	1160	800	2500	4000	750	900	2020	7350	1800	15,0	2950 kg
TX-VM 28000	17.000 kg	7700	1170	830	2950	3800	750	900	2250	8200	1800	15,0	3350 kg

* Bulk density is based on 0.6 kg/dm³.

NOTE: The heating function is optional.

Mixing silos for plastic materials have been planned and built for making the best mixings of granules and/or grinded products; they are moreover suitable for colouring with master or pigments. They are made of painted carbon steel (mod "TV") or in stainless steel (mod."TX"), with capacities from 500 to 28.000 litres (available on demand bigger volumes) Vertical Mixer for granules and rigid flakes mixing, available in different sizes and capacities. Realized in painted steel and stainless steel AISI 304. In option uploading cells, top unloading pipe to fill the big-bag forced load to a faster big-bag emptying timer pause/work on the electrical panel Optimized version for the container transportation with a maximum diameter of 2100mm.

OPTIONALS

- » Large door on cylinder and cone + door along inside screw pipe for better and frequent cleanings.
- » Hinged cover for standard loading hopper.
- » Loading hopper mt. 1x1 for receiving products from big-bag.
- » Additional unloading pipe for big-bags filling.
- » Upper tangential inlet for pneumatic loading.
- » Loading cells.
- » Wheels for mixer moving (only for models up to 5000 litres)
- » Level indicators

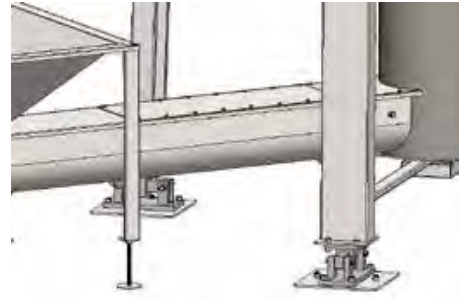

Electronic Control Load Cell

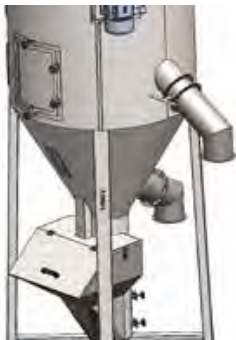

Big-Big side filling and manual shutoff valve



Feeding from big-bag

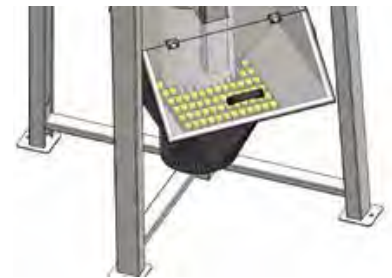

Magnet for Hopper



Drying Option



Pneumatic Discharge Valve + Control

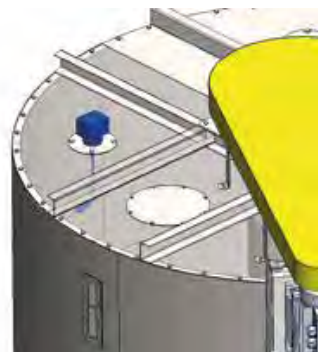

Maximum Level Control



MOBILE MATERIAL BINS

FEATURES:

- » Made of aluminium or stainless steel
- » DIN or special flanges
- » Connections for sensors (level, humidity, temperature, pressure vacuum)
- » Electro-mechanical cover locking for coding systems
- » Runners for forklift operation
- » Feet with castors for mobile use
- » For free-flowing or partially free-flowing bulk materials
- » Filling via pressure (cyclone separator) or vacuum (vacuum hopper loader)
- » Outlet flange for different discharge devices

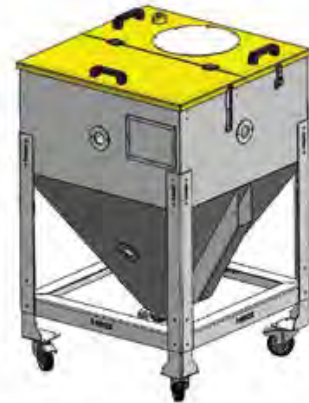

Please let us know if you cannot find a suitable container from our standard products. We can design and manufacture suitable containers for your specific application. We will provide you with a general layout drawing (PDF or STEP file) for verification and the subsequent production go-ahead.

Take advantage of our many years of experience in the design and construction of containers and let us find a suitable solution for your bulk materials and the procedural application together with you. For many special applications we can take advantage of our standard products and adapt our existing designs to your requirements in a cost-effective manner.



ADVANTAGES

- » High processing quality through series production
- » Robust steel frame construction for long-term use
- » Two suction points on the side of the funnel
- » MIN detector can be retrofitted
- » Stackable, which saves space
- » Safe transport by forklift
- » Container tower up to 4000 l filling volume

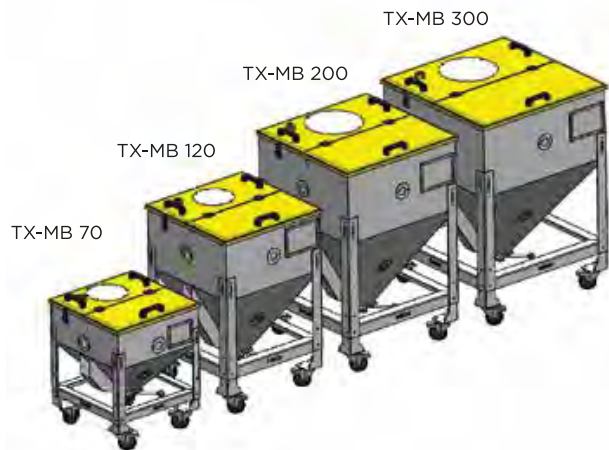

Model	TXMB 70	TXMB 120	TXMB 200	TXMB 300
Volume (l)	110	200	330	500
Capacity (kg)*	70	120	200	300
Width x Length L (mm)	600x600	700x700	800x800	900x900
Height H (mm)	780	1100	1265	1265

*Pouring density is based on as 0.60 kg/dm³



**CONVEYORS AND
SEPARATORS**

Conveyors And Separators

T-MAX conveyors are manufactured in Europe to operate at optimum efficiency, in accordance with your production conditions. Aluminium construction frame, high-temperature resistant band structure, various runner separation systems (separator types) according to the product and runner shape structure, and our CE quality certified conveyors, even under the most severe conditions, provide maximum efficiency.





→ NP

This belt is to be placed under the press for extracting the pressing. Perpendicular position of the conveyor respect the moulding machine. Parallel position of the conveyor respect the moulding machine.

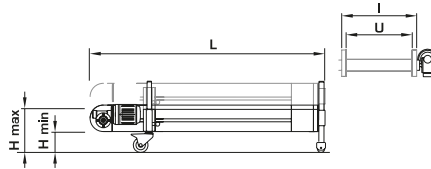

Mod	L	U	I	H min	H max
NP1	1500	250	305	200	400
NP2	1500	350	405	200	400
NP3	1500	450	505	200	400

→ NI

This belt, which is placed parallelly or perpendicularly to the press, allows to collect the pressings in only one place. Perpendicular position of the conveyor respect the moulding machine. Parallel position of the conveyor respect the moulding machine.

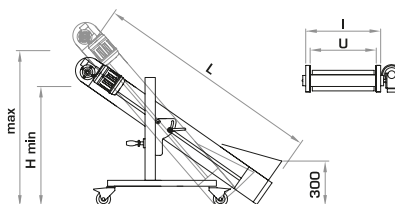

Mod	L	U	I	H min	H max
NI1	1500	250	305	600	1000
NI2	1500	350	405	600	1000
NI3	1500	450	505	600	1000
NI4	2000	250	305	800	1400
NI5	2000	350	405	800	1400
NI6	2000	450	505	800	1400
NI7	2500	250	305	1000	1800
NI8	2500	350	405	1000	1800
NI9	2500	450	505	1000	1800



→ NC

This belt is to be placed next to the press in parallel, either on the operator's side or on the back of the press. Reported dimensions with 35° inclination Parallel position of the conveyor respect the moulding machine. Perpendicular position of the conveyor respect the moulding machine. Conveyor inside of the moulding machine.

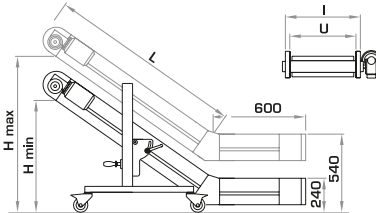

Mod	L	U	H min	H max
NC1	1300	250	750	1050
NC2	1300	350	750	1050
NC3	1300	450	750	1050
NC4	1800	250	1050	1350
NC5	1800	350	1050	1350
NC6	1800	450	1050	1350

→ NS

Multipurpose belt. Its position may be changed according to the production needs. Reported dimensions with 35° inclination. Parallel position of the conveyor respect the moulding machine. Perpendicular position of the conveyor respect the moulding machine. Conveyor inside of the moulding machine.

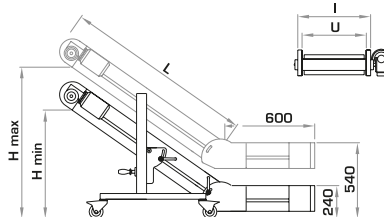

Mod	L	U	I	H min	H max
NS1	1300	250	305	750	1050
NS2	1300	350	405	750	1050
NS3	1300	450	505	750	1050
NS4	1800	250	305	1050	1350
NS5	1800	350	405	1050	1350
NS6	1800	450	505	1050	1350



→ ND

This belt is to be placed next to the press. A blade separator is assembled as standard equipment. Reported dimensions with 35° inclination. Parallel position of the conveyor respect the moulding machine. Perpendicular position of the conveyor respect the moulding machine. Conveyor inside of the moulding machine.

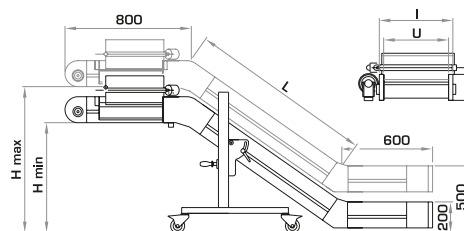

Mod	L	U	I	H min	H max
ND1	1300	250	305	700	1000
ND2	1300	350	405	700	1000
ND3	1300	450	505	700	1000
ND4	1800	250	305	1000	1300
ND5	1800	350	405	1000	1300
ND6	1800	450	505	1000	1300

→ NDS

This belt is to be placed next to the press. A blade separator is assembled as standard equipment. Reported dimensions with 35° inclination. Parallel position of the conveyor respect the moulding machine. Perpendicular position of the conveyor respect the moulding machine. Conveyor inside of the moulding machine.

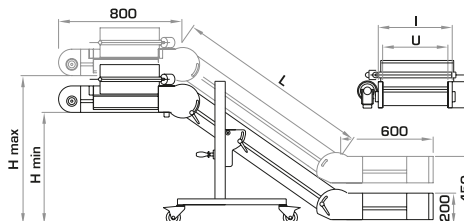

Mod	L	U	I	H min	H max
NDS1	1300	250	305	700	1000
NDS2	1300	350	405	700	1000
NDS3	1300	450	505	700	1000
NDS4	1800	250	305	1000	1300
NDS5	1800	350	405	1000	1300
NDS6	1800	450	505	1000	1300



← NDZ



← NCRS

→ NDZ

Conveyor to place at the side of the injection moulding machine or under the injection moulding machine, suitable to transport parts in box or on working table. This model don't include the flap separator. Reported dimensions with 35° inclination. Parallel position of the conveyor respect the moulding machine. Perpendicular position of the conveyor respect the moulding machine. Conveyor inside of the moulding machine.

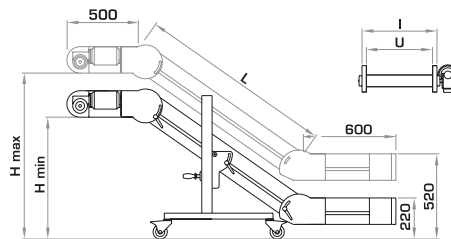

Mod	L	U	I	H min	H max
NDZ1	1300	250	305	700	1000
NDZ2	1300	350	405	700	1000
NDZ3	1300	450	505	700	1000
NDZ4	1800	250	305	1000	1300
NDZ5	1800	350	405	1000	1300
NDZ6	1800	450	505	1000	1300

→ NCRS

Side injection moulding machine conveyor to transport pieces released from the robot and to convey the pieces on a working table or in containers. Reported dimensions with 35° inclination. Parallel position of the conveyor respect the moulding machine. Perpendicular position of the conveyor respect the moulding machine. Conveyor inside of the moulding machine.

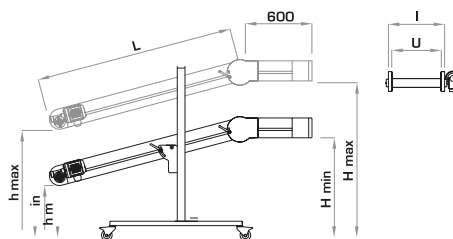

Mod	L	U	I	H min/H max	H min/H max
NCRS1	1800	350	405	500/1000	1000/150
NCRS2	1800	450	505	500/1000	1000/150
NCRS3	1800	550	605	500/1000	1000/150
NCRS4	1800	650	705	500/1000	1000/150
NCRS5	2500	350	405	500/1000	1300/180
NCRS6	2500	450	505	500/1000	1300/180
NCRS7	2500	550	605	500/1000	1300/180
NCRS8	2500	650	705	500/1000	1300/180

→ NPP

Side injection moulding machine conveyor, with connection with the robot and polycarbonate protection or zincplated metallic net, with electric box with outside signal and step by step timer.

Protezione con tettuccio: Lato Dx - Sx Protection guard

Optional:

- Conveyor with special dimensions
- External consent
- End conveyor sensor
- Light-acoustic signal
- Inspection door install on the protection



→ NPS

Auxiliary side wall

Flat conveyor to place at the side of the injection moulding machine to use to discharge the pieces from the robot or it is possible to use like parts assembling moving table. Special length and width available per request.





Mod.	U	I
NV1	250	360
NV2	350	460
NV3	450	560
NV4	250	360
NV5	350	460
NV6	450	560
NV7	250	360
NV8	350	460
NV9	450	560

→ NV

BELT WITH COOLING TANK Complete with mechanical variator NON FLOATING special tray belt FLOATING special tray belt and NON FLOATING special tray belt

→ SR-M/SR-A

S PARATEUR ROTATIF

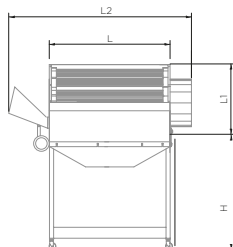

Mod.	L	L1	L2	H
SRM	720	450	1300	1200
SRA	720	500	1300	1200



→ SRA

Separation of small products by rotating rollers.
Setting of the rollers by manual or automatic.

Automatic filling line Weighing system on request
Customised construction, on request Box loading
by conveyor or by robot

linea riempimento automatico automatic filling
line weighing system on request customised
construction, on request box loading by conveyor
or by robot

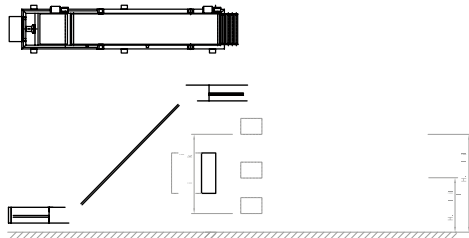
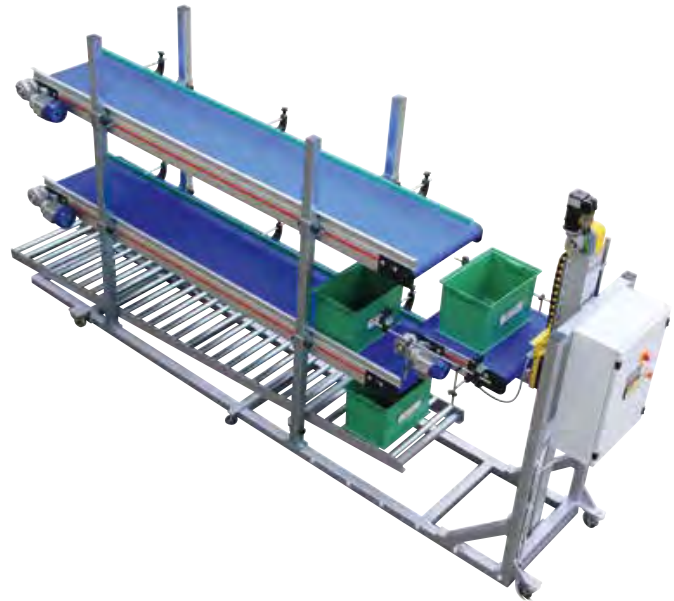

DOUBLE ROLL SEPARATOR

The double cylindrical runner separator can be easily mounted on any T-MAX conveyor. It drops small parts vertically between belt and roller. It separates the longer and larger pieces by driving them over the roller towards a separate container. It is extremely easy to adapt to different products with adjustable product runner sizes.



BLADE TYPE SEPARATOR

It is an excellent choice for small parts and large H structure runner/product combinations. The parts pass beneath the blade and exit the conveyor. The runner and other items that must be separated are pushed by the blade and exit the conveyor's mouth on the side. Blade works with its own Gearmotor and independent control unit. Blade height and exit angle can be adjusted easily according to runner and product dimensions.



DRUM TYPE SEPERATOR

It has versatile usage flexibility. It reduces the cost of separating the runner and the products. It is designed to eliminate factors that affect separation time. It has proven itself by giving very accurate and good results even in the most difficult runner and product combinations. The separation distances of the condition separator can be adjusted according to the product/runner sizes.



SPIRAL SEPERATOR

The spiral separator is an excellent choice for very complex separation problems. In the spiral area, the pieces usually slide apart. The spiral roller movement separates the runner and the product by exiting to a separate location. The distance between the spiral and the slider mouth can be adjusted according to the size of the product and the runner.



→ SR

Rotating slide for the feeding of bags and boxes with fully programmable rotating movement.

→ TVR

Rotating table for the feeding of bags and boxes with fully programmable rotating movement.

Ölçü (Ø) mm
1200/1500





**METAL
SEPARATORS**

FEATURES:

- » Protection of extruders and injection moulding machines
- » Removal of metal from slow or stationary material columns
- » Low installation height
- » Extremely strong housing
- » Own monitoring with diagnosis system
- » Fully-automatic function
- » Proven technology
- » Almost maintenance-free
- » TX-LCS electronic all-metal separators are suitable for metal separation from stationary or slow moving material columns.
- » Slow moving material columns pass the sensor area of the TX-LCS
- » Ferrous or non-ferrous metal parts contained in the material are detected in the detection coil.
- » The detection coil/sensor unit is pushed together with the metal parts by a pneumatic cylinder to the ejection position. Metal contamination is removed on the side together with a small amount of good material. A sluice plate blocks the material supply while this takes place. Due to the very fast material ejection, extruders can also be monitored so that they do not "run empty"
- » After ejection of the metal, the empty sensor unit returns to the initial position and releases the material flow again.

TX-LCS



Electronic all-metal separators of the TX-LCS ("Last Chance Separator") series are used especially in plastics processing with slow moving or "stationary" material columns. They offer the last chance of detecting damaging metal parts and removing them fully automatically, before these disappear into the intakes of extruders or injection moulding machines. Not only are ferrous metals detected, but also non-ferrous metals such as aluminium, copper, brass etc.

Damage to extruder screws and tools or blockage of hot runner systems are therefore reliably prevented. The stable and extremely strong housing of the TX-LCS separators can also be used for mounting of mixers, driers and small conveying equipment.

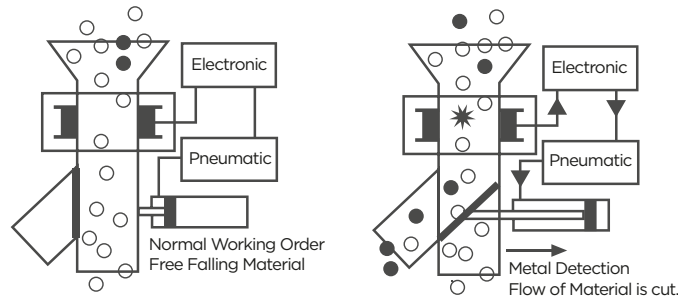

Model	TX-LCS 50	TX-LCS 70	TX-LCS 100	TX-LCS 150
Feeding Input (mm)	50	70	100	150
Flow Capacity (max. Kg/h)	500	1200	3100	5000
Sensitivity (mm ²)*	1,0	1,5	1,5	2,0
Weight (kg)***	30	42	45	60

- It depends on the ease of material flow. This applies to new machines. It is used with special materials. (in large quantities of machines, for example with granules of fiber and metal leaf). It is recommended for units with large feed diameter.
- Maximum sensitivity depends on the diameter of the steel ball. If the material flow is too slow, there may be little loss of precision.
- Body weight (8 kg) not included.

TX-HS

YOUR ADVANTAGES:

- » Protection of products, machines and tools
- » Self-monitoring with diagnosis system
- » Fully automatic operation
- » Universal application possibilities
- » Integrated electronics
- » Proven technology
- » Simple assembly
- » Most simple operation
- » Almost maintenance-free



TX-HS free fall metal separators

TX-HS electronic all metal separators serve for detection and fully-automatic removal of individually arising metallic contamination in free-falling, free-flowing bulk materials. Not only are metals containing iron (ferrous metals) recognised here, but also non ferrous metals such as, e.g. aluminium, copper, brass, etc.

The result is a practically metal-free product. TX-HS all metal separators protect products, machines and tools from damage through metal contamination, surely, reliably and cost effectively.

Operating principle

The free-flowing bulk material drops in free-fall through the shaft of the TX-HS all metal separator. A high frequency alternating current field, produced within an electromagnetic coil, is influenced by metal particles as they fly through the coil. Each metal part sets off an impulse when it falls through the opening of the coil that can be used for control and signal purpose. Metal particles that may be contained in the material are electronically detected as from a certain size and separated fully automatically via a pneumatically operated by-pass from the material flow and ejected.

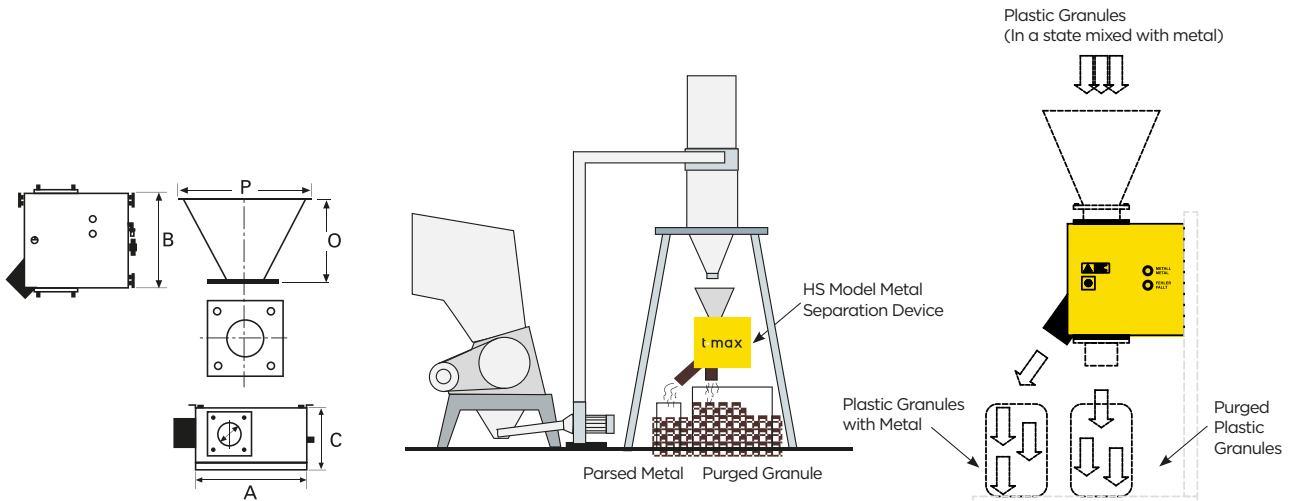

Model	TX-HS 9050	TX-HS 9070	TX-HS 9100	TX-HS 9150	TX-HS 9200
F	50	70	100	150	200
A	380	380	380	380	380
B	300	380	380	600	600
C	155	210	210	350	350

YOUR ADVANTAGES:

- » Protection of machines, tools, products
- » For continuous or intermittently working systems
- » Available for vacuum or pressure conveying lines
- » Maximum throughput corresponding to the conveying performance of pneumatic conveying lines
- » Special mechanical separation prevents collapse of conveying pressure and flow
- » Self-monitoring with diagnosis system
- » Universal use with a connection flange specific to customer requirements
- » Integrated electronics
- » Proven technology
- » Almost maintenance-free



TX-FFS metal separators for pneumatic conveying lines

The TX-FFS series electronic all-metal separators recognise and remove metal particles from bulk materials that are transported in vacuum and pressure conveying lines. The metal recognition and separation takes place "on the fly" with conveying speeds at up to 30 m/s. Special mechanical separation systems are used, depending on the type of conveying (pressure or vacuum conveying, continuous or intermittent). The conveying pressure is maintained during the entire metal separation process.

Apart from ferrous metals, TX-FFS separators recognise and remove all non-ferrous metals. Products, machines and tools therefore are surely, reliably and cost effectively protected from damage through metal contamination.

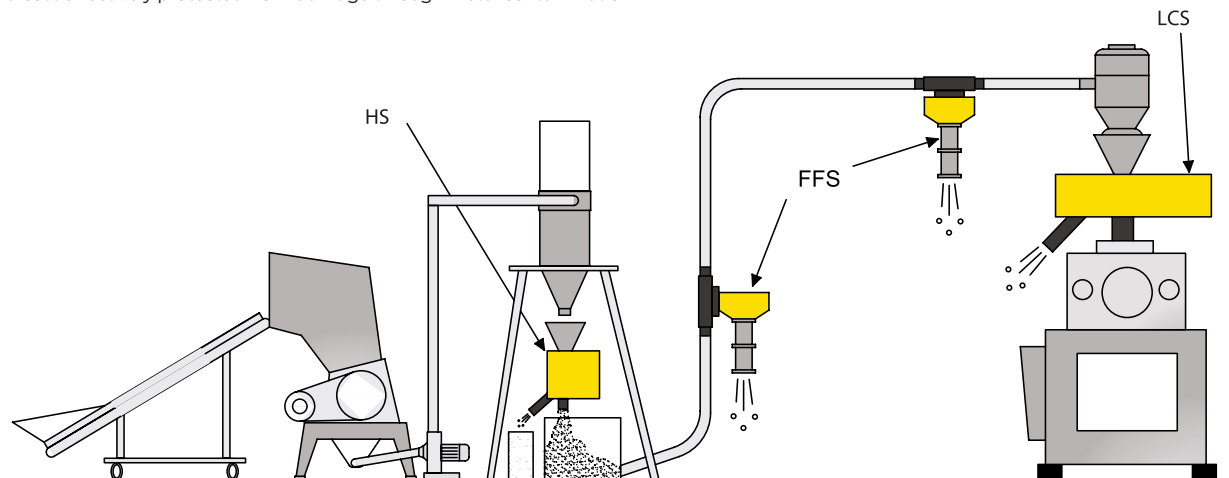

Please call us, for other Hamos Products

Electrostatic Plastic-Metal, Plastic separators, turnkey metal and plastic separation systems.

KWS Model Electrostatic Sorting Machine

Fully automated separation system for mixing electrically conductive and non-conductive materials (metal/plastic, etc.)

EKS Model Electrostatic Sorting Machine

Fully automated separation system for plastic - plastic mixtures. Technology that enables the complete separation of plastics with different properties from each other

MAGNETS



Product Features:

- » Temperature-compensated, high intensity rare earth magnets for superior high temperature operation and exceptional surface-holding force.
- » Two rows 2,5 cm tubes maximize magnetic circuit while allowing ample space for flow.
- » Rugged, 11-gauge stainless steel housing built to support symmetrical compression loads of 4500 kg.
- » Dust-tight welded housing for easy cleaning and durability
- » Drawer gasket cut from ethylene propylene diene (EPDM) to resist heat aging and compression set, and offers much greater durability than sponge rubber.
- » Clear polycarbonate drawer front for easy viewing of product flow and captured contaminants.
- » High-torque nylon knobs resist breakage.
- » Superior cartridge geometry increases reach-out and holding power.
- » Available in 10, 15, 20, 25 cm

■ TX - FF Box Magnets with "Standard Self - Cleaning"

TX-FF 4400-PLS
(100 mm x 100 mm)

TX-FF 4600-PLS
(300 mm x 300 mm)



For over 50 years, T-MAX Magnets have been known in the plastics industry for their ability to deliver superior magnetic separation. Today, T-MAX Magnets remain the plastic industry's most popular choice for extrusion, injection, and blow molding equipment. Designed with the unique needs of the plastics industry in mind, Bunting offers several different models of FF drawers to suit a wide variety of applications. All of our T-MAX Magnets are FULLY customizable. Whether you are working in injection molding, extrusion, or plastics recycling, we can provide you with a custom product to suit your exact needs.

Neodymium Magnet



7-bars Magnet



9-bars Magnet



Square Magnet

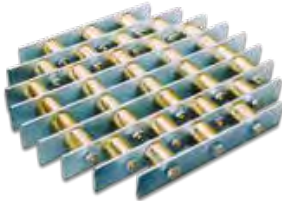

Round Magnet



300x300

Ø 150
Ø 200

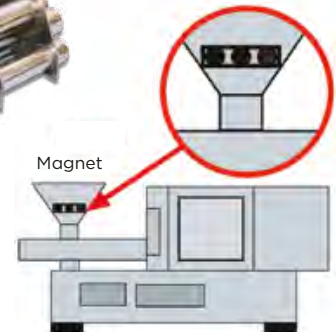

1) In injection machines, the magnet is placed inside the funnel on the machine.

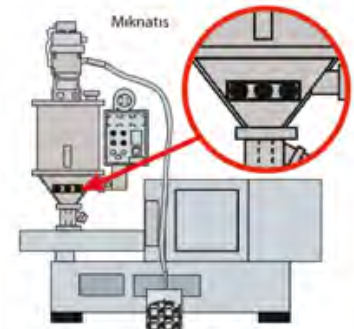

2) In injection machines, the magnet is placed inside the drying silo on the machine.

DIAMETER	MODEL	GAUSS	DIMENSION
Ø 150	Round	2.400	150 mm
Ø 200	Round	2.400	200 mm
Ø 164 and Ø 20	Round	2.400	164-200 mm
300x300	Square	4.500	300 mm
Ø 100	Box	4.500	282 mm
220x220	Neodymium	4.500	220 mm
	With 7-bar	1.800	
	With 9-bar	1.800	

Select Features:

- » Equipped with high temperature-compensated rare earth magnets.
- » Drawer gasket: Viton sponge material rated to 200°C maximum temperature to resist heat aging and compression set.
- » Drawer front constructed from Polysulfone material resists temperatures up to 175°C intermittent temperature operation.
- » High-torque nylon knobs resist breakage at temperatures up to 125°C
- » Rugged, easy-to-clean 11-gauge stainless steel housing built to support symmetrical 4500 kg compression loads.
- » Stainless steel center drawer guide simplifies removal and re-installation of the magnet drawer for quick, easy cleaning.
- » Superior cartridge geometry and construction increases reach-out and holding power while maximizing cartridge life.
- » High-temperature parts are completely interchangeable with the standard T-max magnets

T-max Magnets come standard with super-strong neodymium rare earth magnets powerful enough to capture and hold ferrous particles so small that they are invisible to the naked eye. Neodymium magnets have exceptional surface holding force for more complete removal of contaminants and less chance of "wipe-off," referring to contamination falling off of the magnetic surface and re-entering the product stream.

T-max exclusive highly refined drawer magnets are the only temperature-compensated rare earth magnets available for integration with injection molding machines. Other rare earth drawer magnets can permanently lose their magnetic power at temperatures above 80°C. T-max are guaranteed not to lose magnetic strength when bolted to feed throats operating at temperatures in excess of 80°C. Magnetic energy that strong means guaranteed durability and less downtime for you - plus reduced screw wear and fewer plugged nozzles.

T-max has a dedicated manufacturing area for, meaning that once you place your order, you'll receive your equipment fast. With more magnetic drawer filters on plastic processing equipment than any other brand, our magnetic protection for plastics processors is the industry standard the world over.

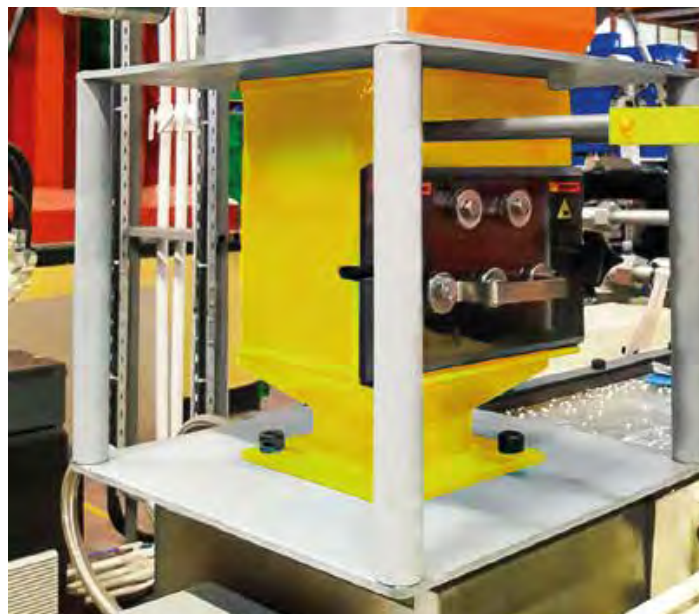

**DRAWER TYPE
MOLD RACKS**



FEATURES

- » Save space and facilitate mold management.
- » The ejector plate of the mold frame can be pumped freely after being loaded, and the storage and retrieval work can be completed easily and quickly in cooperation with the available pulley and manuals hoist
- » The mold frame adopts a removable structure, and all accessories can be combined arbitrarily.
- » The overall structure is scientific and reasonable, and it is firm and reliable after being assembled and formed as required, with high safety.
- » The maximum weight of each grid can reach 100kg/1500kg/2000kg

TXMR



Technical Features

Model	Maximum Load (kg)		Dimensions (LxWxH)	Manual Crane Chain lock Holder (mm) (HxW)	Chain (mm) (a)	Chain Block (kg)
	Lower	2-3 Fold				
TXMR-1000	1000	800	3130x600x2000	500x880	350	1000
TXMR-1500	1500	1000	3430x780x2000	500x1050	350	1500
TXMR-2000	2000	1200	3430x1100x2950	330x1480	450	2000

Dimensions

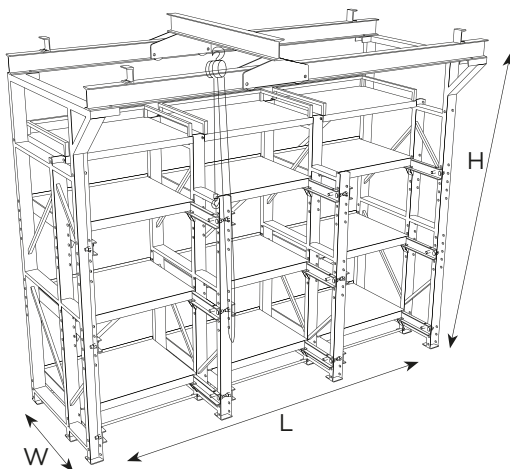

TXMR-2000

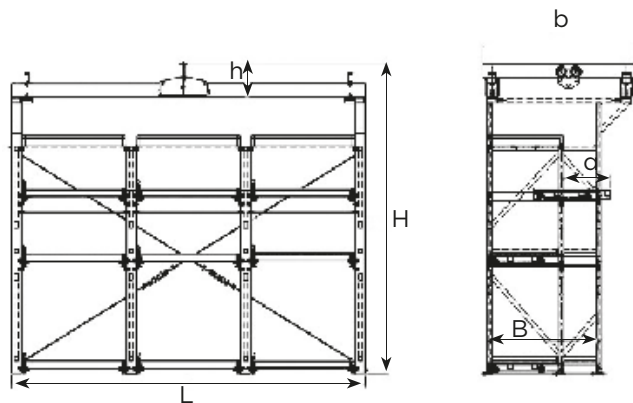

TXMR-1000-1500

C TYPE ONE-WAY FULLY-OPEN DRAWER MOLD RACK

t-max

FEATURES:

- » C type mould rack, the drawers can be opened 100% in one-way.
- » Mainly be used to store the plastic moulds, press die and other kinds of moulds.
- » Large storage capacity to save floor space, easy to manage moulds, improve the workshop cleanliness and efficiency.
- » Drawer assembly design to meet your diversified needs.
- » The layers altitude can be adjusted per 50mm and the quantity of rows can be unlimited assembled.
- » Manual or electrical chain hoists optional.
- » Powder coated finish.
- » Color: light grey Ral-7035, blue Ral-5012.



C332

Model	Size (cm) (L*D*H)	Drawer				Manual Crane	
		Size	Load	Quantity	Opening	with	Load
C331	295*90*220	81*85 (W * D)	1000kg	9	100%	✓	—
C332	(L * D * H)			12		○	—
C341	295*90*250	9				✓	800kg
C342	(L * D * H)			○		—	
C331W	355*90*220	100*85 (W * D)	1000kg	9	100%	✓	—
C332W	(L * D * H)			12		○	—
C341W	355*90*250	12				✓	800kg
C342W	(L * D * H)			○		—	

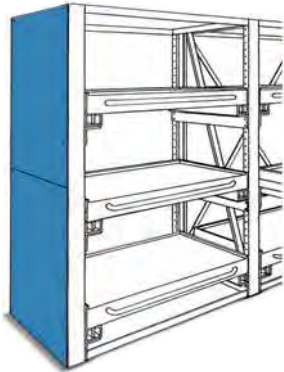

Side Panels

The side panels are available to be supplied.



Pulley&Chain Hoist

The pulley, manual chain hoist and electrical chain hoist are available to be supplied.

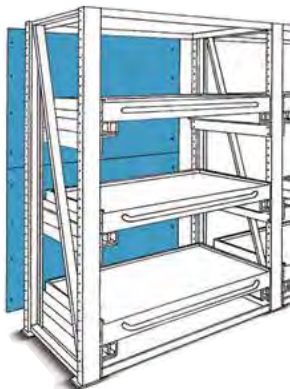

Back Panels

The back panels are available to be supplied.

Rubber Pads for Drawers

The rubber pads for drawers are available to be supplied.

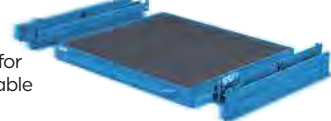

Wooden Pads for Drawers

The wooden pads for drawers are available to be supplied.



Sliding Doors

The sliding doors are available to be supplied.

Floor Bolts

The floor bolts are supplied as standard for every upright. The uprights must be fixed on the floor.



Top Panels

The top panels are supplied as standard. You can put some light things when without the pulley.



FEATURES:

- » H type mould rack,the drawers can be opened 90% in one-way
- » Mainly be used to store the plastic moulds, press dies and other kinds of moulds.
- » Large storage capacity to save floor space, easy to manage moulds improve the workshop cleanliness and efficiency.
- » Drawer assembly design to meet your diversified needs.
- » The layers altitude can be adjusted per 100mm and the quantity of rows can be unlimited assembled.
- » Manual or electrical chain hoist is optional.
- » Powder coated finish.Color:light grey Ral-7035, blue Ral-5012.



Model	Size (cm) (L*D*H)	Drawer				Manual Crane	
		Size (cm)	Load	Quantity	Opening	with	Load
H331	285*95*220 (L* D * H)	80*61 (W * D)	1000kg	9	90%	✓	800kg
H332						○	—
H341				12		✓	800kg
H342						○	—
H351				15		✓	800kg
H352		○	—				
H331A	375*129*200 (L* D * H)	110*75 (W * D)	2000kg	9	✓	800kg	
H332A					○	—	
H341A				12	✓	800kg	
H342A					○	—	

FEATURES:

- » M type mould rack, the drawers can be opened 50% in one-way. Mainly be used to store the plastic moulds, press dies and other kinds of moulds
- » Large storage capacity to save floor space, easy to manage moulds improve the workshop cleanliness and efficiency.
- » Drawer assembly design to meet your diversified needs.
- » The layers altitude can be adjusted per 100mm and the quantity of rows can be unlimited assembled. Manual or electrical chain hoist is optional.
- » Powder coated finish. Color: light grey Ral-7035, blue Ral-5012.



Model	Size (cm) (L*D*H)	Drawer				Manual Crane	
		Size (cm)	Load	Quantity	Opening	with	Load
M331	285*66*220 (L* D * H)	80*61 (W * D)	800kg	9	50%	✓	800kg
M332						○	—
M341						✓	800kg
M342				○		—	
M351				✓		800kg	
M352				○		—	

**DOSING AND
MIXERS**



Volumetric Dosing Units

TCM-30

The TCM series volumetric dosers are suitable for auto-proportional mixing of new materials, regrinds, masterbatch and additives. A brushless DC motor is used in this series. The microprocessor accurately controls the rotation of the high precise dosing screws to squeeze out materials with an accuracy of +/-1% from setpoint. A gear motor with deceleration ratio of 30:1 or 100:1 is coupled to a dosing screw of six models with output ranging from 0.1 -32kg/hr. Double color doser can be supplied to match with two single color doser if required by clients.



TCM-30

FEATURES:

- » Everlasting data memorizer and setting storage.
- » Use brushless dc motor and free from maintenance
- » Microprocessor control, intelligent and accurate in calculation.
- » External signals can be directly interfaced with the control box.
- » Dosing screws are chrome plated for durability.
- » Unit is comprised of standard modules for ease of cleaning, disassembly and interchangeability.
- » Three-tubes hopper magnet is equipped at the base of the single color doser to absorb metal impurities so to prevent the screw of moulding machine from damage.
- » Single color doser takes base blender as an option to make blending more evenly.
- » Blender built-in a standard accessory for double color doser and it can meet client's need for double blending.
- » Main material hopper is a standard accessory for double color doser. It is optional for single color doser



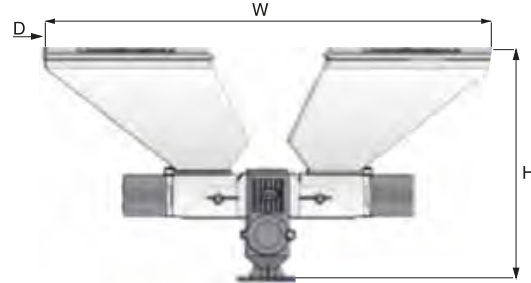
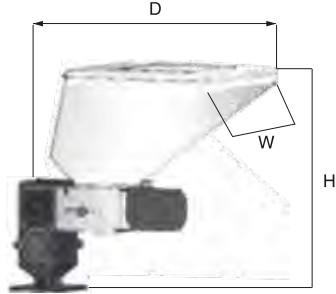

TECHNICAL FEATURES

	TCM-30-16	TCM-30-14	TCM-30-12	TCM-100-16	TCM-100-14	TCM-100-12	TCM-D-30/30	TCM-D-30/100	TCM-D-100/100
Motor Power	0.05	0.05	0.05	0.05	0.05	0.05	0.05X2	0.05X2	0.05X2
Revolution	0-3000	0-3000	0-3000	0-3000	0-3000	0-3000	0-3000	0-3000	0-3000
Mixer Power	0.09	0.09	0.09	0.09	0.09	0.09	0.09	0.09	0.09
Screw Outer Diameter	16	14	12	16	14	12	**	**	**
Output Capacity	1.0-3.2	1.0-20	0.3-10	0.5-15	0.2-8	0.1-4	*	*	*
Hopper Volume	10	10	10	10	10	10	10	10	10
Gear Ratio	30:1	30:1	30:1	100:1	100:1	100:1	30:1/30:1	30:1/100:1	100:1/100:1
Main Material Funnel	Optional	Optional	Optional	Optional	Optional	Optional			
Mixer	Optional	Optional	Optional	Optional	Optional	Optional			
Floor Stands	Optional	Optional	Optional	Optional	Optional	Optional	Optional	Optional	Optional
Dimensions									
Height	580	580	580	580	580	580	580	580	580
Width	530	530	530	530	530	530	900	530	900
Length	290	290	290	290	290	290	290	290	290
Weight	29	29	29	29	29	29	50	29	50

NOTE:

“*” means the output capacity depends on model selected, data of the single color doser can be reference. For example TCM-D-30-16/30 14, output capacity 1.1-32kg/hr.

“**” stands for external diameter of screw is up to model selected. Single color volumetrics add to mixer, add “MS” to the back of the model. All output capacities from above models are based on the data from density 1.2, dia. 2-3 mm masterbatch in a test criteria of continuous running. Voltage 1Ø, 230V, 50Hz.

Gravimetric Dosing Units TGB-600

TGB series weighing mixer adopt the latest single-chip microprocessor, more powerful function, higher speed, and stronger antijamming capability. It has auto compensation ability, when start machine, can automatically calibrate. It is mostly applied in plastic injection, extrusion, or material mix with exact proportion to mold plastic.



TGB-600-4-1R

FEATURES:

- » Adopts single-chip microprocessor design, more powerful function, smaller size and good anti interference ability.
- » Use EEPROM, data will not be lost when power off, battery free.
- » Interface state, contact controller, easy use, can store a lot of formula data (500 set).
- » High speed, high accuracy, AD catch material, more stable.
- » All material will be weighed then mix strictly control precision.
- » Recheck the weight data and material, ensure the precision and accuracy.
- » Can directly install it on molding machine, but need to choose and buy base of mixer.
- » When install on the floor, need to but pneumatic material-stop valve, floor stand, storage bunker and material-inhale box.

TECHNICAL FEATURES

(mm) Model	TGB-40	TGB-80	TGB-200	TGB-600	TGB-1200
L	810	835	920	1085	1230
W	630	675	710	880	1100
H	1040	1140	1220	1585	1850
L1	305	305	340	500	600

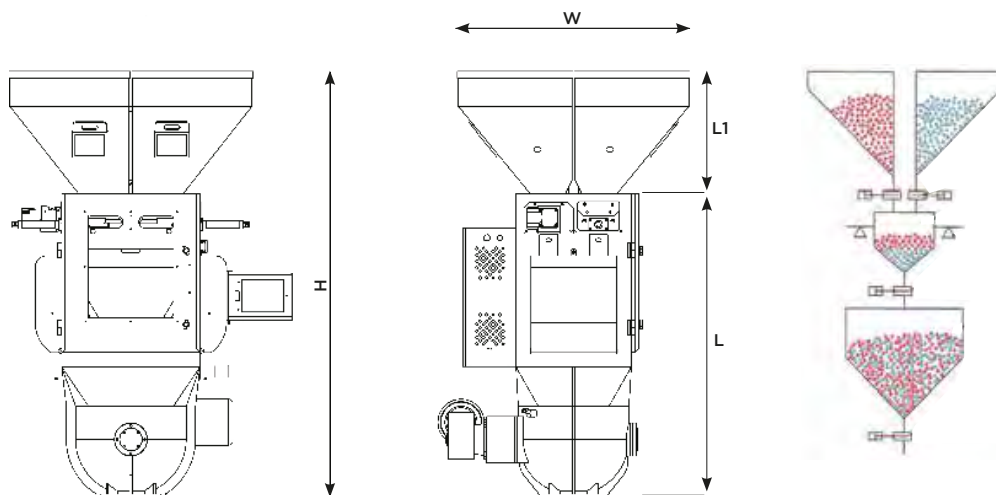

GRAVIMETRIC DOSING UNITS



Model	Number of Groups	Number of Blades	Number of Screws	Maximum Batch Amount	Air Pressure	Motor Mixing Power	Maximum Output			
TGB-40	4	4	—	1	5-6	0.37	40			
		4-1 R	3				1	40		
		4-2 R	2				2	35		
		4-3 R	1				3	30		
	3	3	3				—	50		
			3-1 R				2	1	50	
			3-2 R				1	2	45	
			2				2	—	60	
2-1 R	2	1	1	55						
		4	4	—	80					
		4-1 R	4	3	1	80				
				4-2 R	2	2	65			
4-3 R	1			3	50					
3	3			—	90					
3-1 R	3	2	1	90						
		3-2 R	1	2	70					
		2	2	—	140					
		2-1 R	1	1	120					
TGB-80	4	4	—	2	5-6	0.37	200			
		4-1 R	3				1	200		
		4-2 R	2				2	180		
		4-3 R	1				3	160		
	3	3	3				—	220		
			3-1 R				2	1	220	
			3-2 R				1	2	160	
			2				2	—	350	
2-1 R	2	1	1	240						
		4	4	—	600					
		4-1 R	4	3	1	600				
				4-2 R	2	2	520			
4-3 R	1			3	500					
3	3			—	650					
3-1 R	3	2	1	650						
		3-2 R	1	2	500					
		2	2	—	1000					
		2-1 R	1	1	700					
TGB-200	4	4	—	3.5	5-6	0.55	1200			
		4-1 R	3				1	1200		
		4-2 R	2				2	1100		
		4-3 R	1				3	1050		
	3	3	3				—	1300		
			3-1 R				2	1	1150	
			3-2 R				1	2	1450	
			2				2	—	1350	
2-1 R	2	1	1	1200						
		4	4	—	1600					
		4-1 R	4	3	1	1500				
				4-2 R	2	2	1500			
4-3 R	1			3	1400					
3	3			—	1300					
3-1 R	3	2	1	2200						
		3-2 R	1	2	2000					
		2	2	—	2100					
		2-1 R	1	1	2000					
TGB-600	4	4	—	12	5-6	0.7	2000			
		4-1 R	3				1	2000		
		4-2 R	2				2	1950		
		4-3 R	1				3	2000		
	3	3	3				—	2000		
			3-1 R				2	1	1900	
			3-2 R				1	2	1800	
			2				2	—	1800	
2-1 R	2	1	1	1800						
		4	4	—	1200					
		4-1 R	4	3	1	1200				
				4-2 R	2	2	1100			
4-3 R	1			3	1050					
3	3			—	1300					
3-1 R	3	2	1	1350						
		3-2 R	1	2	1200					
		2	2	—	1600					
		2-1 R	1	1	1500					
TGB-1200	4	4	—	25	5-6	1.5	1500			
		4-1 R	3				1	1600		
		4-2 R	2				2	1600		
		4-3 R	1				3	1550		
	3	3	3				—	1400		
			3-1 R				2	1	1400	
			3-2 R				1	2	1400	
			2				2	—	1300	
2-1 R	2	1	1	1350						
		4	4	—	1200					
		4-1 R	4	3	1	1200				
				4-2 R	2	2	1100			
4-3 R	1			3	1050					
3	3			—	1300					
3-1 R	3	2	1	1450						
		3-2 R	1	2	1350					
		2	2	—	1200					
		2-1 R	1	1	1600					
TGB-1500	2	2	—	30	5-6	1.5	1500			
		2-1 R	1				1	1500		
		3	3				—	1500		
		3-2 R	2				1	1500		
	3-2 R	3	1				2	1550		
			4				4	—	1400	
			4-1 R				4	3	1	1500
								4-2 R	2	2
4-3 R	1	3		1400						
3	3	—		1300						
2-1 R	2	2	—	2200						
		2-1 R	1	1	2000					
		3	3	—	2100					
		3-1 R	2	1	2000					
3-2 R	3	1	2	1950						
		4	4	—	2000					
		4-1 R	4	3	1	2000				
				4-2 R	2	2	2000			
4-3 R	1			3	1900					
2	2			—	1800					
TGB-2000	4	4	—	40	5-6	2.2	2200			
		2-1 R	1				1	2000		
		3	3				—	2100		
		3-1 R	2				1	2000		
3-2 R	3	1	2				1950			
		4	4				—	2000		
		4-1 R	4				3	1	2000	
							4-2 R	2	2	2000
4-3 R	1			3	1900					
2	2			—	1800					

φ, 230V, 50 Hz

- 1) Proportion error is the D-value from set data to actual proportion
- 2) Knife matring is suitable for proportion above 5%, the error can be below +/-0.3%.
- 3) Screw or micro quantity matring is suitable for 0.5% to 5% proportion, the error can be below +/-0.1%
- 4) The result above is got from test with granule of 3-4 diameter, aggregation degree 0.8, continuous running.



Proportional Valves

TPV-38U

The TPV series of proportional valves mix regrind and new materials in a proper proportion, and then send them back to the process machine to achieve a proportional mixing and loading effect. It features directly mounted on loaders or mounted by the pipeline. Besides, it is applicable to loaders and equipped with control box to perform when it other situations.



TPV-38U

FEATURES:

- » Classy appearance, easy installation and operation.
- » Unique design of valve body, made material conveying smoother
- » The performance of solenoid valve is so stable that the air cylinder acts accurately to ensure a proportional mixing of new and regrind materials.
- » Instant recycling the regrind materials to reduce the production cost.
- » Microprocessor control intelligent and accurate.
- » Setting ratio of virgin and regrind.
- » Attractive appearance, and easy to access.

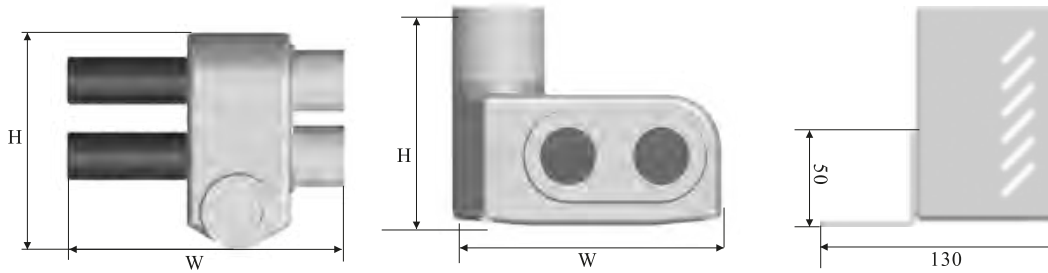
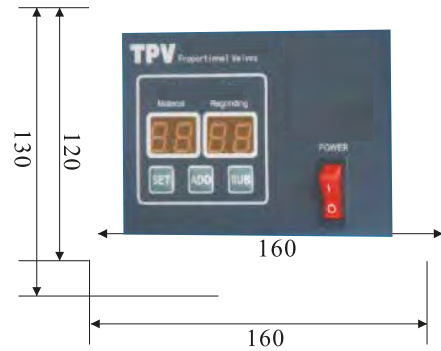

TECHNICAL FEATURES

Model	Air Pressure	Driver	Maximum Flow	Pipe Size	Compressor Air Connection	Electrical Connection	Connection Diameter
TPV-38	3Kgf/cm ²	Air Cylinder	350Kg/hr	38mm	4-6 bar	220 V, 50 Hz	2x38 mm
TPV-50	3Kgf/cm ²	Air Cylinder	550Kg/hr	50.8mm	4-6 bar	220 V, 50 Hz	2x50 mm

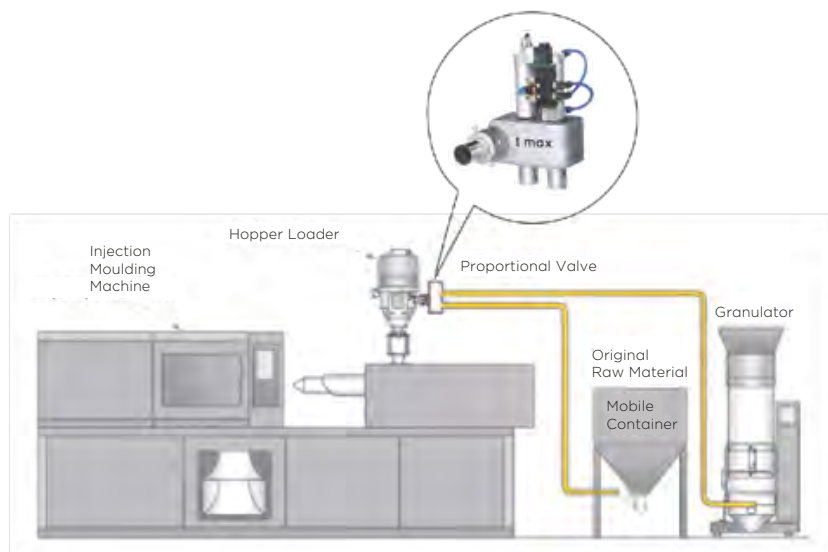



PET
CRYSTALIZER

Pet Crystalizer

- Fixed speed of agitator makes materials not lump together during the crystallization
- High efficiency an deven crystallization
- Simplify and improve drying efficiency
- Materials can be dried under high temperature by using Standard hopper
- Standard cyclone dust collector is applied to dust-rich place,to effectively reduce theload on air-return filter,and the number of times for filter cleaning,thus extend the life on the filter bag.
- With double overheat protectors,it can reduce the possibility of either mechanical or man-made problem
- Equipped with totary valve with good sealing performance,wich can output crystallized material accurately
- Equipped with negative pressure tester to immediately test the ventilation of the filter. Give an alarm when the negative pressure is higher than the setting value, clean the filter to avoid blockage.



ACCESSORIES OPTIONS

- Can be used with dehumidifiers for direct processing
- Auto loader,hopper receiver,magnetic base,suction box are optional for material conveying
- Optional screw loader for stable an deven conveying of un-crystallized material
- External pipeline is optional with the stainless steel configuration
- Optional positive pressure feeding

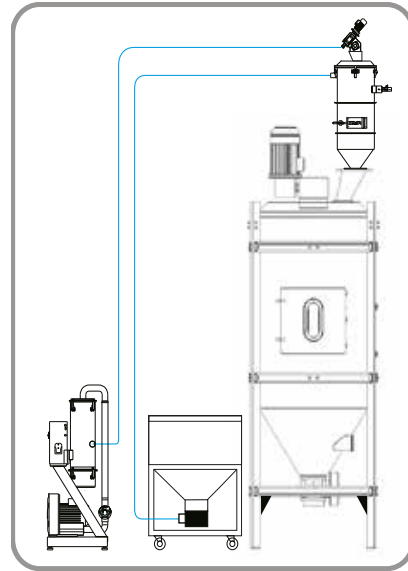

Vakum Yükleme

TCR Applications

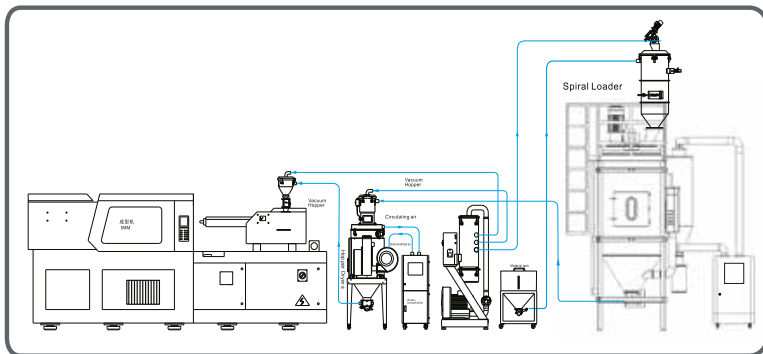

Dimensions

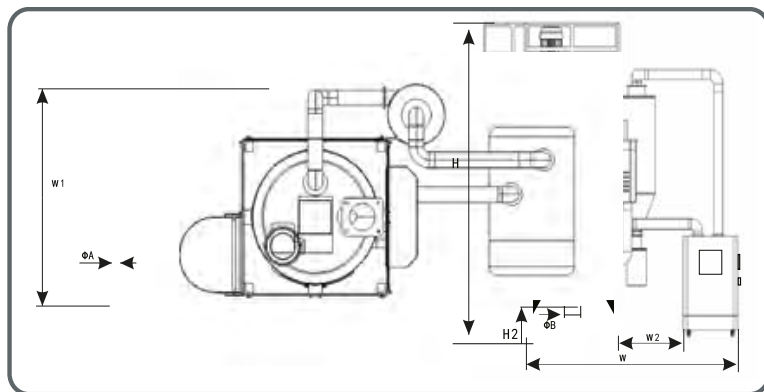

WORKING PRINCIPLE

Once material filling starts, heat blower starts un and material heating begins. Control cabinet would stop sending signals to auto loader when material filling amount is higher than material level switch. Then material heating lasts for a while. When temperature sensing needle detects the value of reaching the set crystallized temperature. Material would be conveyed out via feeding device meanwhile, as material level in hopper lowers gradually, filling device starts to supply the un-crystallized material accordingly to realize the continuous crystallization process. When temperature sensing needle detects the temperature value of stopping material conveying, feeding device halts. If temperature rises again to reach the set crystallized temperature, feeding device will be activated to work so that the continuous crystallization process can be realized through this of circle.

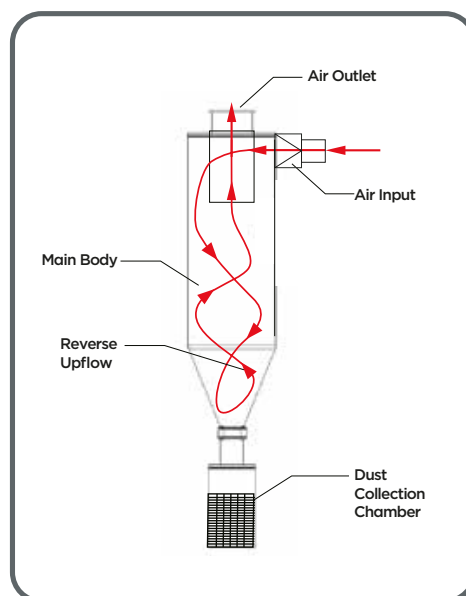
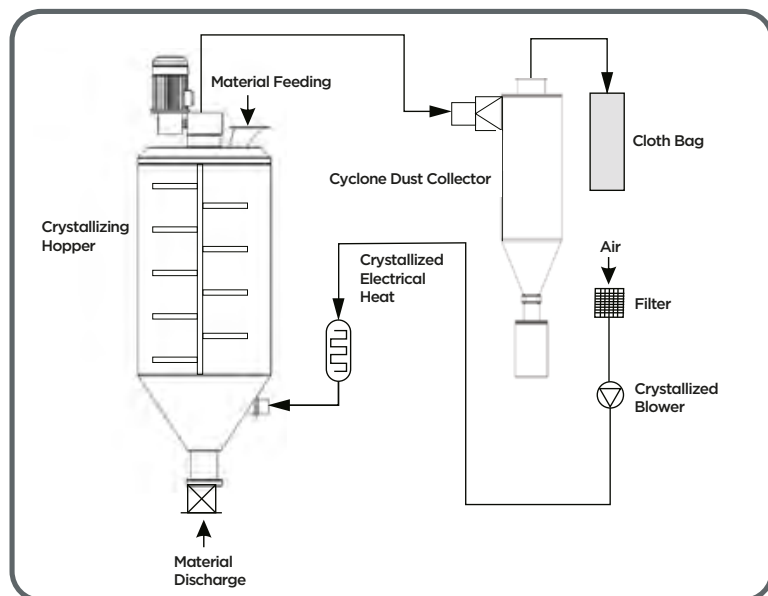

APPLICATIONS

TCR closed-loop crystallizers are used for constant crystallization of un-crystallized PET virgin or regring material. Processed materials then can be dried and dehumidified directly. This system mainly consists of heating elements, insulated hopper and agitator screw mixing device. After un-crystallized PET materials fed into the hopper, the system starts crystallization and agitator starts blending to prevent formation in lumps. Crystallized materials can be conveyed to material storage bin or into drying hopper.

Model	TCR-160U	TCR-450U	TCR-900U	TCR-1600U	TCR-2500U
Heater Power (kW)	12	24	48	96	128
Fan Power (kW)	0.55	2.2	3	7.5	15
Mixing Motor Power (kW)	0.25	1.1	1.5	1.5	4
Maximum Yield (kg/hr)	50	150	300	500	750
Hopper Capacity (L)	160	450	900	1600	2500
Y (mm)	2380	3850	4450	5350	5670
Y1 (mm)	280	720	1040	860	1270
H2 (mm)	380	1060	1185	1260	1270
G (mm)	1040	2370	2890	3570	4050
W1 (mm)	1140	1440	1930	2190	2350
W2 (mm)	...	800	800	800	800
A (Inch)	3	5	6	8	8
B (Inch)	4	4	5	5	5
Net Weight (kg)	235	500	865	2290	2790

PET (Properties of Substance)

PET material is well-used in textile fiber, food and chemical packaging, tape stripes, industry thread, heat-resistantant dishware. Air bubble and chapping will take place due to its high moisture content. With this drying demand and the development on plastic industry, t-max provides a series of secured and reliable drying and dehumidifying Technologies for for PET molding and other PET product manufacturers T-max's PET system with great technology can meet various application demands.

- Bottle and blank making
- Thermal forming film and sheet making
- Strapping tape and industrial yarns making
- Tubing making
- Waste recovery making

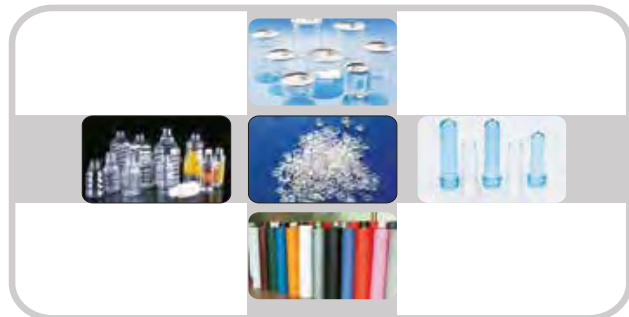



**COOLING AND
HEATING UNITS**

New Coolmax Series Chiller

t-max products are under the guarantee of Tepro Makine. Our products have been carefully selected with the expertise and experience gained as a leading company in the sector. With the understanding of "best quality at an affordable price", products that increase productivity and provide flexible usage advantages are offered under the brand t-max.

New Product



Modular Design

T-MAX cooling systems can work alone as well as in groups and have the feature of working in harmony with T-MAX or other brand coolers.

Main Body

The main body is made of galvanized steel and covered with epoxy with a minimum thickness of microns. In this way, t-max coolers are effectively protected, and their appearance and value can be preserved for many years. Minimum energy consumption, high efficiency.

Ease of Maintenance

To provide easy and fast service, easy access to all parts is provided. Panels made of galvanized steel are easily removable and portable. It has a durable and stylish appearance with 60-micron thick epoxy paint.

- » CE Standard
- » Reasonable price
- » Modular design
- » Stainless steel pump (optional)
- » Very quiet condenser
- » Scroll or screw-type refrigerant compressor
- » Optional electronically controlled expansion valve
- » Continuous control of the process fluid
- » Continuous automatic adjustment of refrigerant capacity
- » Low current draw at start-up
- » Easy and economical maintenance
- » Stock products and spare parts
- » 24/7 technical support



Compressor

The circulation of the refrigerant in the system is provided by a scroll resistant to overloads or by a screw-type compressor for larger flow rates. Depending on the model, it can be connected to an independent gas circuit or with a twin compressor, the compressors are switched on and off depending on the desired temperature. In this way, maximum efficiency and co-aging are ensured.



Evaporator

Thanks to the maximum water turbulence method, Shell&tube evaporators are self-cleaning. The tank surfaces of the system, which work with the dry expansion logic of water/gas separation, are insulated against unwanted heat transfers. In the system called "Counter-Flow", maximum cooling efficiency is achieved by flowing water and exposure flows in opposite directions.

- » Maximum heat transfer is achieved.
- » Unwanted heat transfers are prevented.
- » A high degree of efficiency has been achieved thanks to the compressors working with low gas pressures.



Fans

Carefully selected fan brands from leading fan manufacturers are used for T-MAX cooling groups.

Water Cooling Circuit

The cooling circuit is made of copper pipes and includes the following components.

- » For all models:
- » Expansion valve with external balancing (Optional electronic valve);
- » Valve on the liquid line;
- » Dryer Filter;
- » Solenoid valve;
- » Liquid and humidity indicator;
- » Crankcase heater;
- » High and low-pressure Switches;
- » Oil level indicator;
- » Safety valve on the compressor;
- » High Pressure and low-pressure gauge.



Water Circuit

The water system includes the following for all models:

- » Collector and fittings;
- » Evaporator;
- » Flow Meter;
- » Pressure indicator;
- » Pump Accessories



Electrical Panel

The control panel is mounted on the unit. Therefore, it is protected in the IP55 protection class. The door lock is connected to the main switch per European standards. The wiring complies with the IEC standard. The electrical panel includes magneto-thermal protection for fuses, compressors and fans, according to IEC 947. Circuit start for compressors, directs for screw (optional soft start, star-triangle) and scroll compressors, section Auxiliary power is protected by fuses.



Control

Cooling is controlled by a microprocessor. Electronic control is carried out by a control system with Corel Software installed. Programming, input shows nominal values (data operation) and problems, input is made directly on the screen. There is also a visual and audible alarm. The parameters remain in the memory of the control system in case of a power cut.

Microprocessor

- » The microprocessor controls all the functions of the device and any adjustments are made from here.
- » The operation can be entered directly by the microprocessor values and parameters.
- » Each chip can control up to 4 compressors.
- » There are audible and visual alarm buttons for various functions continuous monitoring. The data memory is preserved in the event of a power failure in the system.
- » Set points have been changed and setting changes can be made on the screen.



KEY FEATURES:

- » Inlet and outlet temperature display
- » ID and image alarms
- » Optional features include two pumps and alternate operating control.
- » "Free cooling" with optional modular control valve
- » Reed switch delay during start-up
- » Compressor(s) operating counter hours
- » Rotation direction of compressors
- » Pump function soft close
- » Electronic thermostat antifreeze
- » Stay away-start
- » Manual operation
- » Manual reset
- » Alarms:
 - » High and low pressure, oil and overheating
 - » Compressor overload
 - » Overload and overheat fans Freeze Flow switch
 - » Eprom error



New COOLMAX SERIES CHILLER Air Condenser Chiller Cooling Units

Model	ENX	ENX16	ENX22	ENX30	ENX38	ENX45	ENX55	ENX70
Cooling Capacity (15°C-25°C)	kW/ Kcal/h	24 / 20.640	36 / 31.000	46 / 39.560	56 / 48.160	77 / 66.220	85 / 73.100	105 / 90.300
Cooling Capacity (07°C-35°C)	kW/ kcal/h	15 / 12.900	26 / 22.360	32 / 27.520	39 / 33.540	50 / 43.000	56 / 48.160	71 / 61.000
Compressor Nominal Power	kW	4,54	6,65	9,00	11,20	12,75	18,10	20,50
Number of Compressor	Adet	1	1	1	2	2	2	2
Number of Cooling Circuit	Adet	1	1	1	1	1	1	1
Power Level	Adet	1	1	1	1/1	1/1	1/1	1/1
Power Refrigerant Gas	-	R410A	R410A	R410A	R410A	R410A	R410A	R410A
Water Section								
Rated Water Flow	m³/h	2,5	3,8	5,1	6,4	7,2	10,3	12,2
Evaporator Type	-	Plate Type	Plate Type	Plate Type	Plate Type	Plate Type	Shell and Tube	Shell and Tube
Hydraulic Connections	Inch	1 "	1 1/2 "	2 "	2 "	2 "	2 1/2 "	2 1/2 "
Tank Volume	dm³	100	200	250	250	250	325	325
Pump Power	HP	1,5	1,5	3	3	4	4	5,5
Rated Pump Pressure	Bar	2,5	2,5	2,5	2,5	2,5	2,5	2,5
Fan Section (Axial)								
Total Air Flow	m3/h	12.500	12.500	25.000	25.000	37.500	37.500	37.500
Number of Fans	Adet	1	1	2	2	3	3	3
Fan Motor Power	kW	0,8	0,8	1,6	1,6	2,4	2,4	2,4
Total Electrical Data								
Electrical Connection	V/Hz	400/3/50	400/3/50	400/3/50	400/3/50	400/3/50	400/3/50	400/3/50
Rated Power Drawn	kW	7,1	9,5	12,75	15	19,8	25,7	29,6
Maximum Drawn Current	A	14,9	20	23	31,5	41,6	54,0	62,2
Dimensions and Weight								
Length	mm	1270	1370	1910	1910	2830	2830	2830
Width	mm	705	800	1000	1000	1190	1190	1190
Height	mm	1410	1770	1855	1855	2330	2330	2330
Empty Weight	kg	270	350	450	460	1060	1060	1060
Operating Weight	kg	370	200	685	710	1310	1385	1385



New COOLMAX SERIES CHILLER Air Condenser Chiller Cooling Units

ENX90	ENX100	ENX130	ENX160	ENX185	ENX230	ENX280	ENX340	ENX370	ENX430
118 / 101.480	137 / 117.820	156 / 134.160	210 / 180.600	236 / 202.960	312 / 268.320	388 / 333.680	488 / 419.680	556 / 478.160	624 / 536.640
80 / 68.800	96 / 82.560	108 / 92.900	147 / 126.420	165 / 141.900	218 / 187.480	272 / 233.920	342 / 294.120	389 / 334.540	437 / 375.820
26,00	29,00	35,20	46,50	52,00	76,80	84,40	104,00	120,00	134,80
2	2	2	4	4	4	4	4	4	4
1	1	1	2	2	2	2	2	2	2
1 / 1	1 / 1	1 / 1	2 / 2	2 / 2	2 / 2	2 / 2	2 / 2	2 / 2	2 / 2
R410A	R410A	R410A	R410A	R410A	R410A	R410A	R410A	R410A	R410A
14,8	16,6	20	24	29,4	40	48	59	67,4	75,6
Shell and Tube	Shell and Tube	Shell and Tube	Shell and Tube	Shell and Tube	Shell and Tube	Shell and Tube	Shell and Tube	Shell and Tube	Shell and Tube
2 1/2 "	2 1/2 "	2 1/2 "	3 "	4"	5 "	5 "	5 "	6 "	6 "
325	325	350	600	600	600	N/A	N/A	N/A	N/A
5,5	5,5	10	10	10	10				
2,5	2,5	2,5	2,5	2,5	2,5				
37.500	48.000	50.000	80.000	80.000	120.000	120.000	160.000	160.000	200.000
3	2	4	4	4	6	6	8	8	10
2,4	3,4	3,2	7,2	7,2	10,8	10,8	14,4	14,4	18
400/3/50	400/3/50	400/3/50	400/3/50	400/3/50	400/3/50	400/3/50	400/3/50	400/3/50	400/3/50
35,7	40,0	50,4	66,9	72,9	103,8	103,6	128,8	146,4	166,3
74,9	83,9	105,9	140,4	153,1	217,9	217,6	270,5	307,4	349,2
2830	2830	4450	4450	4450	4400	4400	5650	5650	7100
1190	1190	1190	1190	1180	2200	2200	2200	2200	2200
2330	2330	2350	2450	2450	2500	2500	2500	2500	2500
1060	1250	1540	1650	1750	1920	2450	3385	3450	4810
1385	1575	1890	2250	2350	2520	2450	3385	3450	4810





**TEMPERATURE
CONTROL UNITS**

Temperature Control Units

TM-W

The TM-W series of water heater are used to heat up the mould and maintain this temperature. Besides, they can also be used in other similar applications. High temperature water from the mould is cooled by direct cooling and then sent to the pipe heaters via high-pressure pump for heating to a constant temperature. With our optimised design, water can reach a maximum 120 C. Equipped and the accurate PID multi-stage temperature control system can maintain an accuracy of +/- 1C.

FEATURES:

- » PID multi-stage temperature control system can maintain a mould temperature with accuracy +/- 1 C
- » Multiple safety devices can automatically detect performance and indicate this via visible alarm.
- » Accurate temperature control achieved by direct cooling and quick heat transfer by automatic water supply facility.
- » Inner parts made from stainless steel to ensure corrosion-free operation.
- » Attractive appearance, easy to Access and maintain.

- » Applicable scope:
- » Heaters are used to heat up the mould and maintain this temperature. Beside they can also be used in other similar applications.
- » System Flowfor TM-W (indirect cooling)
- » High temperature water returns to the machine and then be pressured by pump to the pump to the heaters, After being heated, water will be forced to mould and continue the circle. In the process, if the temperature is too high, the system will activate the solenoid valve to let cooling water cool down the temp directly until the water is down to the system requirement. If the temp. Keep increasing and reach to the set point of EGO, system will alarm and stop operation.



Model	Maximum Heat	Form of Cooling	Heater Power (kW)	Pump Power (kW)	Maximum Pump Flow (L/dak.)	Maximum Pump Pressure (bar)	Connection Dimensions (inch)	Device Dimensions (HxWxD) (mm)	Weight
TM-W 610W	Water 120°C	Direct	6	0.55	30	4.5	3/8"(2x2)	680x295x835	60
TM-W 920W			9	0.75	45	6.0	3/8"(2x2)	680x295x850	65
TM-W 1240W			12	1.5	90	5.5	3/8"(4x2)	880x350x900	85
TM-W 2480W			24	3	160	5.5	1"(1x2)	950x400x980	135
TM-W 610W-D			6x2	0.55x2	30x2	4.5	3/8"(4x2)	680x590x850	100
TM-W 920W-D			9x2	0.75x2	45x2	6.0	3/8"(4x2)	680x590x850	110
TM-W 1240W-D			12x2	1.5x2	90x2	5.5	1"(2x2)	880x700x900	145
TM-W 610W	Oil 200°C	Indirect	6	0.55	30	4.5	3/8"(2x2)	680x295x850	64
TM-W 920W			9	0.75	45	6.0	3/8"(2x2)	680x295x850	69
TM-W 1240W			12	1.5	90	5.5	3/8"(4x2)	680x350x900	90
TM-W 2480W			24	3	160	5.5	1"(1x2)	950x400x980	145
TM-W 610W-D			6x2	0.55x2	30x2	4.5	3/8"(4x2)	680x590x850	110
TM-W 920W-D			9x2	0.75x2	45x2	6.0	3/8"(4x2)	680x590x850	120
TM-W 1240W-D			12x2	1.5x2	90x2	5.5	1"(2x2)	880x700x900	155



**THERMOREGULATOR
UNITS**

t-max Dualmax Series Heating-Cooling together

DUALMAX

New Product

With its new Dualmax series, T-MAX has accomplished the heating or cooling process in the mold through a single data and device.



FLEXIBLE USE IN PLASTICS PROCESSES;

Single or dual zone heating and cooling combined units are water-cooled units with Condensers equipped with integrated standard, high pressure, or booster pumps. T-MAX contributes to the optimum reduction of cycle times in processes with new series devices, occupies less space next to them and takes place in the business as a part of the machine. High pressure and flow pumps ensure stable mold temperatures with high control precision thanks to the heating system. Thanks to the "Free Cooling Valve" offered as an option, it works as much as it needs and economically.

With its wide product range, it offers a suitable model and capacity range. With the touch screen control panel, you can see every movement and temperature of the device on the instant screen. It provides the opportunity to continuously monitor the set and instantaneous values and makes a great contribution to keeping the cycle time to a minimum.

Maxikbul series offer a range of options with two different pump pressures and flow rates, up to 6-48 kW heating power and 195 kW cooling capacity.

SP = Standard pressure and high flow
HP = High pressure and high flow pumps

The use of high-quality and first-class components that make up the device, together with the testing of the Maxikil series under the most demanding conditions, ensures that it performs with the highest efficiency for many years, even under the toughest operating conditions



ITS ADVANTAGES:

- » Synchronized operation and adaptation with the machine and process to be used
- » Contribute to reducing cycle times by up to 50%
- » Smart energy use
- » Energy-saving with Free Cooling valve integration
- » Mold drain kit
- » Visualization and communication interface software
- » On-screen display of heat, flow and pressures on the inlet and outlet points.



MOLD TEMPERATURE CONTROL

- » Mold temperatures have a direct impact on cycle time and product quality. Temperature control is extremely important and requires precision.

OPTIMUM MANUFACTURING PROCESS

- » Increasing production capacity, eliminating waste and wait times.
- » Better product quality, surface appearance and tensile strength.
- » Reducing production costs, low waste and energy costs



Technical Products and Spare Parts



Automotive and Sub-Industry



Packaging Production



Medical Products and Parts

PROCESS GAINS

- » High efficiency and excellent repetition
- » Providing the best cooling conditions and stability
- » Set values independent of operating conditions
- » Pressure-flow and temperature control of two separate processes (optional)
- » High sensitivity in process temperatures
- » Continuous and controlled cooling values
- » Continuous and efficient cooling process with minimum temperature difference in mold temperatures
- » Reliable quality and device structure
- » Permanent solutions to known and usual cooling problems (sweating, surface and visual disturbances size problems).
- » Strong integration between machine, operator and device.

USER GAINS

- » Low energy consumption and fast commissioning
- » Pumps with high efficiency and low energy consumption
- » Low heat losses
- » Quick mold change by eliminating mold preheating and wait times
- » Low maintenance cost
- » Minimal environmental impact, 80% lower cooling gas content than a central chiller.
- » High energy savings thanks to the independent Free Cooling valve in each device.



Home Appliances and Sub-Industry



Dual Zone Units

STANDARD FEATURES:

- » "7" color display control panel
- » Multi-language option
- » Help menu, usage and troubleshooting instructions
- » Graphical indications of symptoms of main study variables
- » Complete view of all water and cooling parameters for easy comprehension of working principles
- » % readings and screen reflections of compressor usages
- » Reading the output temperature values for each zone
- » Reading the flow and return pressure values for each zone separately
- » Flow indicator separately for each zone (Optional)
- » Calculation of pressure and flow differences (Optional)
- » Metric or imperial value selection in the standard user panel.
- » Automatic Free Cooling mode (Optional)
- » Remote start-stop function (Optional)
- » High / low pressure differential protection
- » Protection in sensor connections (against cut-off and short-circuit)
- » Frost protection
- » Deviation curve at set values
- » Long-term signal of setpoint deviation
- » Up to 1000 records with SD card in 50 alarm control panels
- » Automatic air purge and water filling
- » Motorized cooling control for each zone
- » Process pump specific to each region
- » High-efficiency circulation pump
- » Filter in the water inlet
- » Filter at return process water inlet
- » By-pass valve suitable for standard pressure settings
- » Audible alarm
- » Heavy-duty transport wheels



OPTIONS AND ACCESSORIES

Serial connection: Transport to the central control panel with interface protocols and different serial connections.

Audible alarm: In addition to the additional audible alarm, it can also be integrated with an illuminated alarm if requested.

Separate and independent operation: A customer-specific device model is designed to work completely independently, suitable for some special applications and processes. For this, please contact our sales department.

Tower kit: If the device will be fed from an open tower or cooling unit, we can offer a tower kit to prevent pollution that may occur in the condenser and to eliminate the risk of contamination.

Flow meter and ambient temperature indicators Insulation kit, if lower temperatures are required

DIGITAL CONTROL, SAMPLE SCREEN IMAGES

HOME USER PAGE

- » Variable values of all units are displayed on the screen, including water regime and cooling regime temperatures and pressures.
- » Active or deactivated function indicators of compressors, heated pumps, free cooling valves and 3-way valves inside or outside the performance set values with easy-to-understand display colors colored indicators.

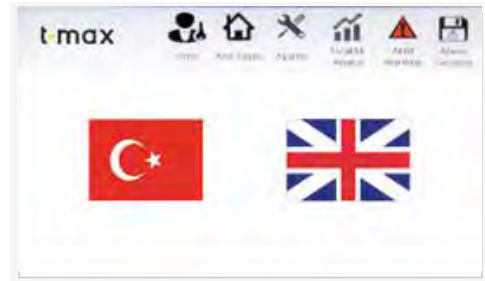

"CHILLER COOLING SECTION" PAGE ON THE MAIN USER SCREEN

- » Indicators including all cooling temperatures and pressures. Besides this, side cooling and superfast heating value page.

MAIN USER ZONE 1 AND ZONE 2 SELECTION PAGE

- » All pump values indicators, flow and return pressures, P calculated flow values (instant and set values, optionally including flow values) and pump and heating kW values.
- » Graphical indicators including pump performances and temperatures

CHILLER PERFORMANCE PAGE

- » A graphical representation of Chiller performance related to setpoint over a 60-minute time frame is displayed.
- » Graphical display of compressor loads
- » Screen reflections of cooling capacity, power consumption and COP values as indicators



PAST RELATED ALARM MEMORY

- » Extra information indicators for each alarm or late preference
- » All alarm definitions, All alarm list descriptions and troubleshooting suggestions by user language

GENERAL FEATURES:



COOLING COMPONENTS

- » Scroll compressors with high efficiency and very low noise level.
- » With the Shell & Tube Evaporator, the classic problems of clogging or heat exchanger leaks do not occur.
- » Condenser pressure control, continuously controlled working pressure with pressure valve.
- » Dual alarm, bilateral high gas pressure control on mechanical and software
- » Ecological refrigerant complies with European standards and directives.

INTERNAL CONNECTIONS AND THEIR COMPONENTS

- » It is designed to provide constant pressure and flow to both the process and the evaporator.
- » It is designed to provide constant pressure and flow to both the process and the evaporator.
- » Use of one or two process pumps, specially designed, high flow and durable and leakproof sealing kits.
- » Wide product range pump flow 20-450 m3/h
- » It provides a constant water regime to the evaporator with the circulation pump.
- » Efficiently working heating elements.
- » Safety thermostat.
- » Proportional modulation valve for each zone for precise temperature control.
- » Stainless steel installation and connections inside the device.
- » Insulated stainless steel balance tank.

MKM Series	Unit	SINGLE SECTION (HEATING / COOLING)							
		MKM 5/3	MKM 9/6	MKM 12/6	MKM 22/6	MKM 25/12	MKM 40/12	MKM 52/12	MKM 70/24
t-max Code		260. MKM0503	260. MKM0906	260. MKM1206	260. MKM2206	260. MKM2512	260. MKM4012	260. MKM5212	260. MKM7024
Cooling Capacity (*)	kW	5	9	12	22	25	40	52	70
	kcal/h	4300	7740	10320	18920	21500	34400	44720	60200
Heating Capacity	kW	3	6	6	6	12	12	12	24
Compressor Power (max)	Adet	1	1	1	1	1	1	1	1
	kW	0,7	1,31	1,74	3,21	3,62	5,71	7,54	10,22
	HP	3,5	3,5	4	6	7	12	15	20
Pump (SB**)	HP	1	1	1	1,5	2	3	3	5,5
	lt / min	36	65	86	150	180	285	370	500
	bar	3	2,9	2,6	2,6	2,8	2,9	2,5	3,1
Internal Pump	HP	0,5	0,5	0,5	0,5	1	1	2	3
Nominal Power	kW	5,2	8,8	9,24	11,45	17,9	20	36	46
Total Power	kW	7,1	10,1	12,85	16,6	20,5	24,7	41,8	40
Sound Level	db (A)	38	38	39	40	40	40	40	40
Capacity	lt	20	20	20	20	30	30	30	40
Net Weight	kg	175	190	205	225	310	360	560	625
Connection Diameters	Ø	1/2"	1"	1"	1" 1/4	1" 1/4	1" 1/2	1" 1/2	2"
Dimensions Width-W	mm	500	500	500	500	550	550	550	1000
Length - L	mm	1000	1000	1000	1000	1200	1200	1200	1800
Height-H	mm	1200	1200	1200	1200	1360	1360	1360	1400
High Pressure	Bar	5,6	5,1	4,8	5,1	5,3	5,4	5,3	4,9
	M3/h	9	9	9	16	16	28	28	28
	power	2 HP	2 HP	2 HP	3 HP	5,5 HP	10 HP	10 HP	10 HP

ELECTRICAL AND CONTROLLING EQUIPMENT

- » Electrical control panel, safety key with lock
- » Electrical circuit protection for compressors and pumps
- » Microprocessor control
- » 7-inch Touchscreen color screen
- » Visualization with the possibility of communication with the known interface software with central control or process machines (optional)
- » Control of cooling and water cycle completely from the screen with pressure and temperature sensors
- » Visual functions showing other parameters such as selected language alarm, fault, and so on.
- » Selection of Language on the screen, appropriate solution suggestions for malfunctions and alarms, description of intervention steps.
- » Working with +10 C sensitivity and alarm feature with proportional integrated intelligent control
- » Mold water filling and discharging procedures
- » Standard audible alarm
- » Port for visual alarm mounting



CHASIS;

- » Epoxy painted main body
- » Easy intervention with removable side panels
- » Compact design and solid wheels

MKM Series	Unit	DOUBLE SECTION (HEATING/COOLING)							
		MKD 5/3+3	MKD 9/6+6	MKD 12/6+6	MKD 22/6+6	MKD 25/12+12	MKD 40/12+12	MKD 52/24+24	MKD 70/24+24
t-max Code		260. MKD0503	260. MKD0906	260. MKD1206	260. MKD2206	260. MKD2512	260. MKD4012	260. MKD5224	260. MKD7024
Cooling Capacity(*)	kW kcal/h	5 4300	9 7740	12 10320	22 18920	25 21500	40 34400	52 44720	70 60200
Heating Capacity	kW	3+3	6+6	6+6	6+6	12+12	12+12	24+24	24+24
Compressor Power (max)	Adet	1	1	1	1	1	1	1	1
	kW	0,72	1,31	1,75	3,21	3,62	5,8	7,65	10,22
	HP	3,5	3,5	4	6	7	12	15	20
Pump (SB**)	HP	1/1	1/1	1/1	1,5 / 1,5	2/2	3/3	3/3	5,5/5,5
	lt / min	36	65	86	150	180	285	370	500
	Pump	3	2,9	2,6	2,6	2,8	2,9	2,5	3,1
Internal Pump	HP	0,5	0,5	0,5	0,5	1	1	2	3
Nominal Power	kW	9	15,5	16	17,5	29,9	33	62	64,75
Total Power	kW	10,9	16,8	18	19,7	32,5	38	68	72,6
Sound Level	db (A)	38	38	39	40	40	40	40	40
Capacity	lt	20	20	20	20	30	30	30	40
Net Weight	kg	260	265	260	265	365	460	625	695
Connection Diameters	Ø	2 X 1/2"	2 X 1"	2 X 1"	2 X 1"	2 X 1"	2 X 1 1/4"	2 X 1 1/4"	2 X 1 1/2"
Dimensions Width-W	mm	500	500	500	500	550	550	550	1000
Length - L	mm	1000	1000	1000	1000	1200	1200	1200	1800
Height-H	mm	1200	1200	1200	1200	1360	1360	1360	1400
High Pressure	bar	5,6	5,1	4,8	5,1	5,3	5,4	5,3	4,9
	max. flow	9	9	9	16	16	28	28	28
	m3/h power	2 HP	2 HP	2 HP	3 HP	5,5 HP	10 HP	10 HP	10 HP

MKM Series	Unit	WATER COOLED CHILLERS							
		MKW/5	MKW/9	MKW/12	MKW/22	MKW/25	MKW/40	MKW/52	MKW/70
t-max Code		260. MKW0005	260. MKW0009	260. MKW0012	260. MKW0022	260. MKW0025	260. MKW0040	260. MKW0052	260. MKW0070
Cooling Capacity	kW kcal/h	5 4300	9 7740	12 10320	21 18060	25 21500	40 34400	52 44720	70 60200
Compressor Power	Piece	1	1	1	1	1	1	1	1
	kW	0,7	1,31	1,74	3,21	3,62	5,71	7,54	10,22
	HP	3,5	3,5	4	6	7	12	15	20
Pump	HP	0,5	0,7	1	1	1	1,5	2	2
	lt / min	15	25	33	60	72	113	150	200
	bar	2,9	3,1	3,2	2,9	2,8	2,8	3,1	2,6
Nominal Power	kW	1,4	2	2,5	4,21	4,62	7,92	9,75	12,42
Total Power	kW	1,9	2,73	3,42	5,76	6,32	10,85	13,35	17,01
Sound level	db (A)	38	38	39	40	40	40	40	40
Capacity	lt	20	20	20	20	30	30	30	40
Net Weight	kg	175	190	205	225	310	360	560	625
Connection Diameters	Ø	1/2"	1"	1"	1" 1/4	1" 1/4	1" 1/2	1" 1/2	2"
Dimensions, Width - W	mm	500	500	500	500	550	550	550	1000
Length - L	mm	1000	1000	1000	1000	1200	1200	1200	1800
Height - H	mm	1200	1200	1200	1200	1360	1360	1360	1400
High Pressure	BAR	5,6	4,6	5	5,2	5,1	5,6	5,6	5,1
	Max. flox m3/h	9	9	9	16	16	28	28	28
	power	1	1	1,5	3	3	5,5	5,5	5,5



**CYCLONE DUST
COLLECTORS**



CYCLON DUST COLLECTORS (ZYKLON) TTZ50

T-Max/TEPRO with its experience in the designing and installation of central feeding systems over 20 years, has started a solution-oriented study to extend the service life of vacuum, filter, and fan lines by the users' feedback.



TTZ-50

- » Raw material loading in the plastic compounding process has evolved in time from manual to fully automatic systems by central feeding.
- » Standard investment units like the main machinery in today's almost all of new set up facilities have a general problem in the vacuum lines and loading systems due to dust.
- » There are too many various reasons for dust pollution. Dust and particulates may be caused by movement inland or sea transport, it may occur while internal convey from warehouse to machines site too
- » It's can be due to the compound structure of the raw material (high calcite and titanium additives) or may occur while the crushing process of the raw materials or with environmental causes.

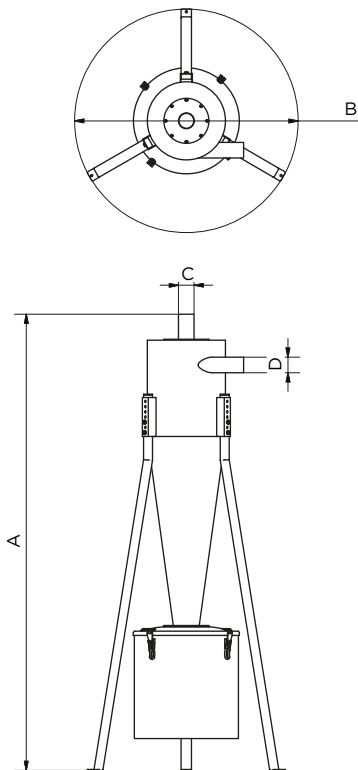

- » The biggest detrimental effect of dust and similar particle pollution while in loading may damage the elements that form the system.
- » The foremost of these is the fan filters. irregular maintenances and non-replacement filters may lead the major damages to the centerpiece of the system as fan.
- » These failures lead to heavy stress for the processes and maybe running losses due to a total down of the system with the raw material cut-off from hours to days.
- » To avoid potential risks, the system needs routine maintenances and new filter or spare part replacements with high cost and time losses.

TECHNICAL FEATURES

A	B	C	D
1574 mm	Ø860 mm	Ø45 mm	Ø45 mm
1574 mm	Ø860 mm	Ø60 mm	Ø60 mm

ADVANTAGES

- » Reduces dust pollution by collecting up to 99% of dust
- » Extends to the service life of filters by 10 times with the mechanic separation unit.
- » Extends to filter treat and replacement period.
- » Increases vacuum efficiency.
- » Reduces electricity consumption least 30%
- » Purifies internal flap and keeps clean against dust and particle pollution.
- » Saves time and budget by the minimum maintenance costs.

T-Max/TEPRO proudly presents one of the results for extending the service life of the vacuum, filter, and fan lines by its experience and solution-oriented studies from users' feedback in the designing and installation of central feeding systems over 20 years. First prototype was designed in 2011 and the same year was launched as a result of all these long-term experiments. The unit called "TTZ-50" has reduced the mentioned problems and maintenance costs and extended the Fan Filter service life. Besides, frequent blade failures in the fan have been eliminated and it has become an essential part of central feeding systems. Due to its cyclonic design, the "TTZ-50" unit enables the collection of dust and particles smaller than the granule size filtered from the raw material with the vacuum.

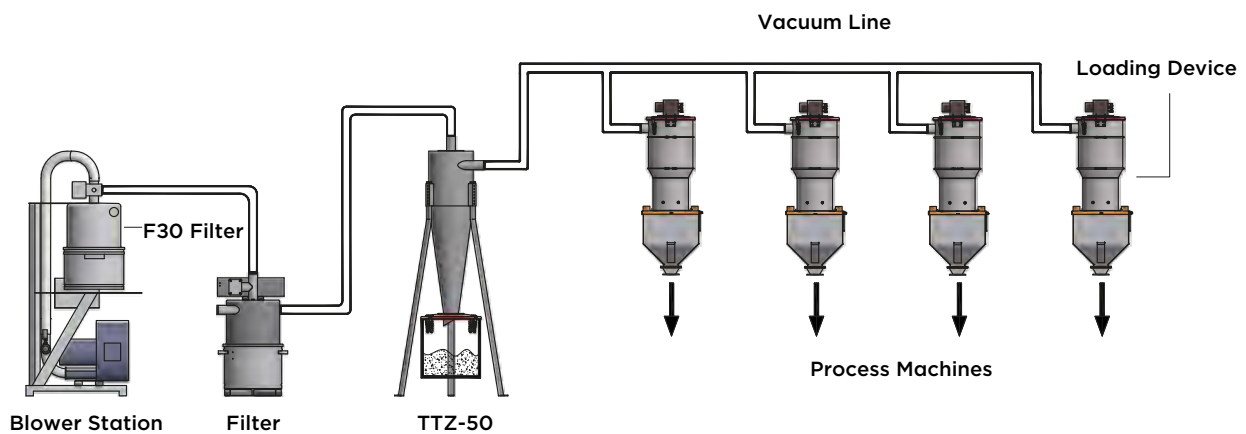

**COMPONENTS FOR VACUUM
AND MATERIAL LINES**



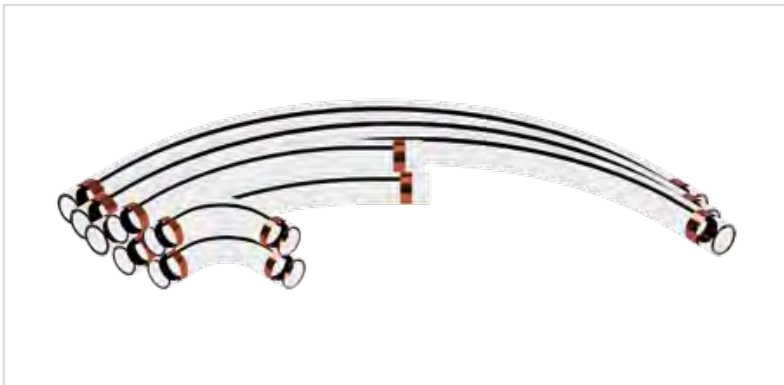

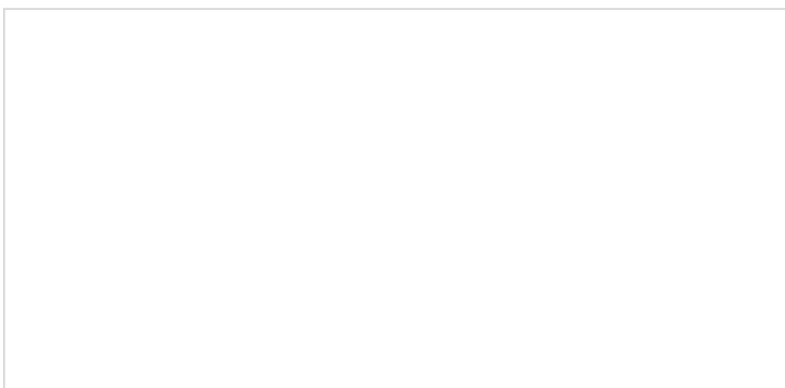







**MONO AND DOUBLE
CHAMBER SILO AND
SILO FEEDING UNITS**

SYSB and SYRB Models offer capacity options with different versions and features in T-MAX Silo loading units. You can easily choose according to the required capacity. While SYSB mostly serves storage points such as small capacities, low volume silo hoppers, SYRB is designed for high capacity and high volume silos. If desired, the parts in contact with the raw material are supplied as stainless steel.

FEATURES:

- » Wide product range
- » Raw material loading capacity from 1 ton to 20 tons
- » Long-life against corrosion with Stainless Steel material
- » Synchronous operation with Silo Level equipment and Advanced Control Panel
- » Efficient and soundproof blower
- » Anti-wear hardened rotary valve blade and body
- » Rotary valve models specific to granular and powder materials



High loading capacity with soundproof Roost Blower 20.000 kg/h



Big Bag direct unloading option

ITS ADVANTAGES

- » It ensures that plastic raw materials in the form of granules, powders and flakes are fed into the silos by being emptied into the hopper with bags, automatic bag opening machine, big-bag sacks, or octabin.
- » Easy to use thanks to its compact structure
- » Integrated operation with control panels of silos
- » Hopper or discharge outlets suitable for tanker discharge
- » Mobile use possibility



SYSB and SYRB Models				
Model	Feeding Diameter (mm)	Blower Power (kW)	Loading Capacity (kg/h)*	Press-touch Height (Horizontal/Vertical)
Silomax SYSB15	80	5,5	1500	5-20 m
Silomax SYSB30	70-80	7,5	2-3.000	5-20 m
Silomax SYSB50	90-100	9	5000	5-20 m
Silomax SYRB100**	90-100	15	8-10.000	5-20 m
Silomax SYRB150**	100-110	22	12.15.000	5-20 m
Silomax SYRB200**	125	30	17-20.000	5-20 m

The loading capacities given in the table are calculated based on the bulk density of 0.65 kg /dm³ and the delivery heads given above. A blower sound isolation cabinet is optional.



Silo loading units working with the Suction Pressure Principle



Two different raw material loading at the same time with the Double Chamber Silo Loading Unit SYRB



Compact Structure - Easy Movement



Single Chamber Silo Loading Unit SYSB



**MULTI-FLOW
BLENDING SILOS**

HOMOGENEOUS MIXING HAS NEVER BEEN SO EASY

With T-MAX Multi-Flow Mixing Silo Technology, it is absolutely necessary to make a homogeneous mixture before the plastic raw materials enter the process or packaging machine immediately after the production. Today, many companies do this by using horizontal or vertical mechanical mixers. Certain problems experienced in these mixer types are as follows;

FEATURES

- » Unnecessary waste of time in raw material changes.
- » Difficulty in cleaning inside the silo and limited intervention areas inside the silo.
- » Increased dust amounts in friction-induced raw materials.
- » Undesirable crushing and deformities in granular structures.
- » Heating of the granules because of the excessive friction and thus surface damage.
- » Sudden and long-term failures due to mechanical or bearing.
- » The need for lubrication in bearings or red bushing bearings and
- » Risks of oil dripping into the raw material.
- » Constant spare part needs, especially in the production of glass fibre reinforced raw materials, due to wear on the spiral leaves or wear of the inner tube.
- » Breakage and damage of the spiral leaves due to metal fatigue due to continuous operation.
- » Contamination risks in raw materials
- » Long maintenance times and high maintenance costs.
- » T-max has developed "Multi-Flow Silo" technology to eliminate all these and similar problems and to ensure uninterrupted production efficiency.
- » It has solved all the problems thanks to the gravity mixing method it has developed and its conical and internal structure design.
- » Depending on the raw material properties and structure, various gravity mixing methods are preferred. Some of them are given in the image below for information only.
- » According to the test results to be made by T-MAX expert engineers and the raw material structure and variety, the most suitable design will be suggested for your business.
- » We test your raw material in our test centre in our silo factory and decide on the most suitable silo volume and the mixer method to be applied.

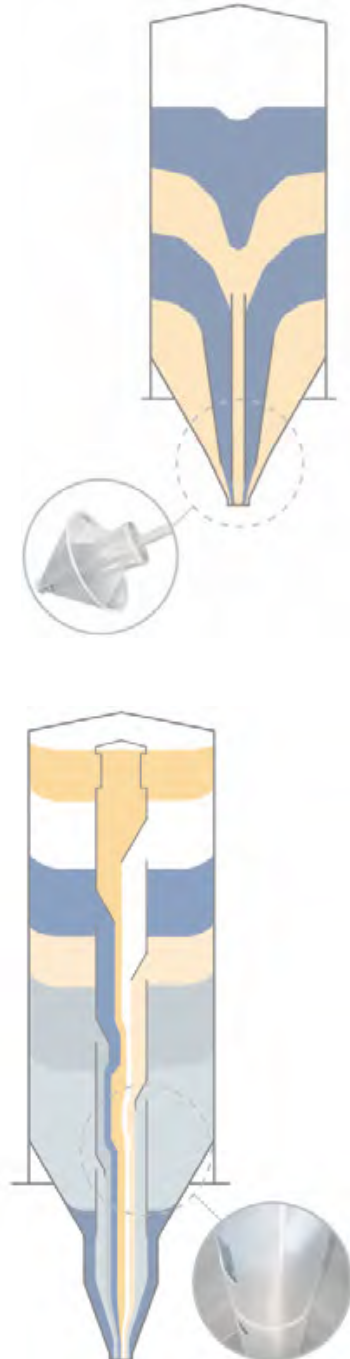

Different mixture and application methods according to raw material structures.



	Multi-Flow Silo	Multi-Flow Silo	Multi-Line and Multi-Stream Silo
Powder, easy-flowing and 50-500 µm	✓	✓	(✓)
Granules, easy-flowing, 200-300 µm	✓	✓	✓
Powder, hardly-flowing raw material types	✓	✓	(○)
	✓ Proper	(✓) Limited Application	(○) Improper



FEATURES:

- » A wide variety of silos and products range between 1 m³ -250 m³
- » Fast, perfect, and continuous homogeneous mixing.
- » Very fast cleaning, no auger, windows in conical or cylindrical body.
- » Material with a high risk of wear due to flanged connection
- » Quick and easy lower taper change in use.
- » Dust-free and undamaged raw material structure.
- » Maintenance-free design. Zero maintenance expense.
- » It eliminates the known and experienced mechanical mixer problems.
- » Continuous or batch working flexibility.
- » Possibility to be applied to new interior or exterior silos.
- » Easy adaptation to internal or external silos in the business.
- » More suitable structure and design for occupational safety.



ALUMINUM SILOS



FEATURES:

- » Single or double layer, Long or short bottom design.
- » Special alloy Aluminium or SST 304 material option
- » Modular panel silo design
- » Opportunity to choose size-volume in special dimensions according to the business area
- » Delivery is made with many options included.
- » Fill tube
- » Ports for level sensor
- » Manhole, air evacuation, control shafts on the silo roof
- » Climbing ladder, roof railing, silo passageways
- » Manufacturing with 600-900 discharge angle depending on raw material flow characteristics.
- » Static and dynamic calculation report per earthquake regulations.



Today, one of the most important equipment of automatic raw material transfer systems in high-capacity plastic production facilities is indoor or outdoor storage silos. In this way, while contributing to the more efficient use of what is indoor or outdoor, the stocking of raw materials becomes regular at the same time. Storage silos are manufactured from aluminium or SST 304 material according to customer demands.

In addition to silo models designed in standard volumes and ready-made dimensions, T-MAX offers silo features suitable for needs and raw material characteristics. In addition, we offer solutions suitable for crushing, PET flake, powder-free flow, or all kinds of hard flow raw materials with our wide range of options. In this regard, we provide technical support to all our customers and help them in silo selection. Thanks to the silo, raw materials are not affected by climatic conditions. It helps the process to be stable. silos; It can be used to store commercially available plastic raw materials without any special features.

ADVANTAGES

- » Long-life against corrosion
- » Easy and fast installation
- » Raw material, time, and labour savings thanks to direct filling from a silo or in-line container or tanker.
- » Packaging costs such as bags, big-bags and obtains are reduced when bulk raw materials are purchased with containers.
- » It eliminates demurrage costs with planned logistics activities.
- » It prevents raw material mixing with POKE-YOKE or coded silo filling connections.
- » Instant capacity is obtained in the silo with min or max level and instant radar level control.
- » By providing data transfer to the server or local computer communication between departments is facilitated.
- » Thanks to instant reports, raw material consumption can be controlled at any time and can be monitored continuously.



ENGINEERING AND TECHNICAL CONSULTING SERVICE

COMPUTER-AIDED ANALYSIS AND DESIGN:

The required silo body thickness and foundation calculation are determined by computer-aided analysis according to the area where the silo will be installed, the size and volume of which is determined according to customer needs, earthquake regulation, snow load, wind load, safety factor, and raw material pouring density.

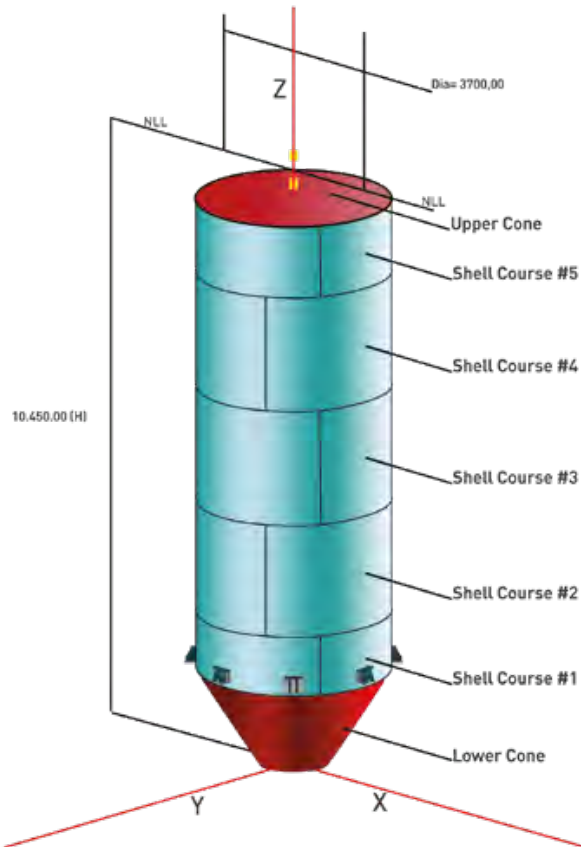

WELDING TECHNOLOGY:

Our silo productions in line with the demands of our customers are done by our internationally certified welders who are experts in their fields without compromising on technique and quality.

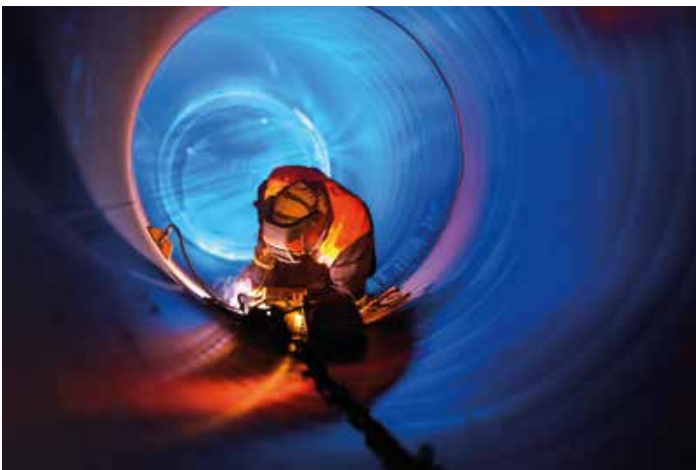

FEATURES:

- » Special Alloy or Stainless-Steel material
- » Welded joint
- » Conical angle according to raw material property
- » Monitoring raw material stocks instantly
- » Long-life against corrosion
- » Design suitable for food and occupational safety
- » Easy and fast installation

ADVANTAGES

- » It eliminates costly storage in the production area.
- » It prevents the raw material from being adversely affected by weather conditions.
- » It reduces the risk of foreign matter mixing with the raw material.
- » When applied together with the central loading system, it prevents unnecessary raw material movement within the enterprise.
- » It provides the possibility of direct delivery of raw materials to the machines.

Footed, cylindrical silos are generally used for economical and reliable storage of granular, powder, and flake plastic raw materials between 1.5-25 m³. Space-saving is achieved by using intermediate stocking silos for companies that have a shortage of space in the business. It is manufactured with special alloy Aluminium or SST-304 material to ensure a long service life against corrosion. Special designs can be made in desired sizes and dimensions.

ØD	m ³	A (mm)	H (mm)
Ø1250	1,5	1000	2500
Ø1250	3	2000	3500
Ø1250	4	3000	4500

ØD	m ³	A (mm)	H (mm)
Ø1910	7	2000	4000
Ø1910	10	3000	5000
Ø1910	13	4000	6000

ØD	m ³	A (mm)	H (mm)
Ø2400	12	2000	4500
Ø2400	16	3000	5500
Ø2400	21	4000	6500
Ø2400	25	5000	7500

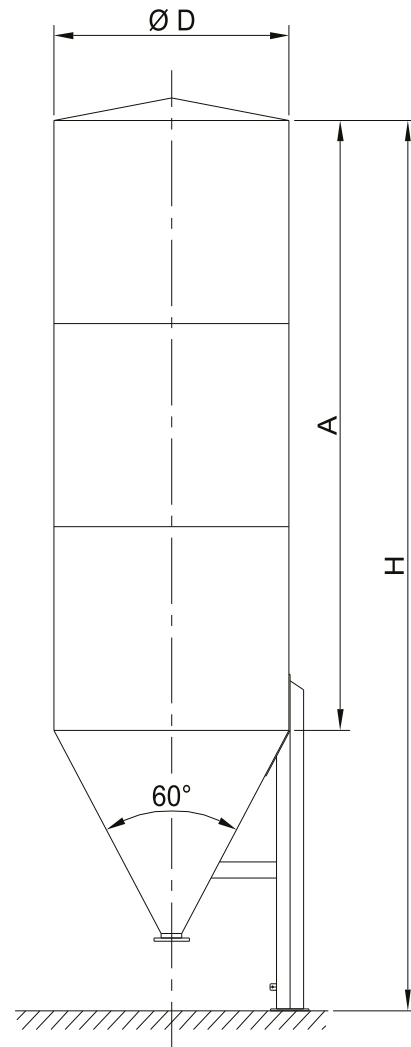

SINGLE CHAMBER SILO WITH CYLINDRICAL LEGS

t-max

FEATURES:

- » Special Alloy Aluminium or Stainless-steel material
- » Welded joint
- » Conical angle according to raw material property
- » Instantly tracking raw material stocks
- » Long-lasting structure against corrosion
- » Design suitable for food and work safety
- » Easy and fast installation feature

It is used in order to stock plastic raw materials in the form of granules, powders and flakes.

ØD	m ³	A (mm)	B (mm)
Ø2865	36	4,800	8,000
Ø2865	49	6,800	10,000
Ø2865	62	8,800	12,000
Ø2865	75	10,800	14,000
Ø2865	88	12,800	16,000
Ø2865	100	14,800	18,000
Ø2865	113	16,800	20,000

ØD	m ³	A (mm)	B (mm)
Ø3500	50	4,200	8,000
Ø3500	69	6,200	10,000
Ø3500	88	8,200	12,000
Ø3500	107	10,200	14,000
Ø3500	127	12,200	16,000
Ø3500	146	14,200	18,000
Ø3500	165	16,200	20,000
Ø3500	184	18,200	22,000

ØD	m ³	A (mm)	B (mm)
Ø3820	81	6,000	10,000
Ø3820	104	8,000	12,000
Ø3820	127	10,000	14,000
Ø3820	150	12,000	16,000
Ø3820	173	14,000	18,000
Ø3820	196	16,000	20,000

ITS ADVANTAGES

- » It eliminates costly storage in the production area.
- » It prevents the raw material from being adversely affected by weather conditions.
- » It reduces the risk of foreign matter mixing with the raw material
- » When applied together with the central loading system, it prevents unnecessary raw material movement within the enterprise.
- » It provides the possibility of direct delivery of raw materials to the machines.
- » It is used to stock plastic raw materials in the form of granules powders, and flakes.

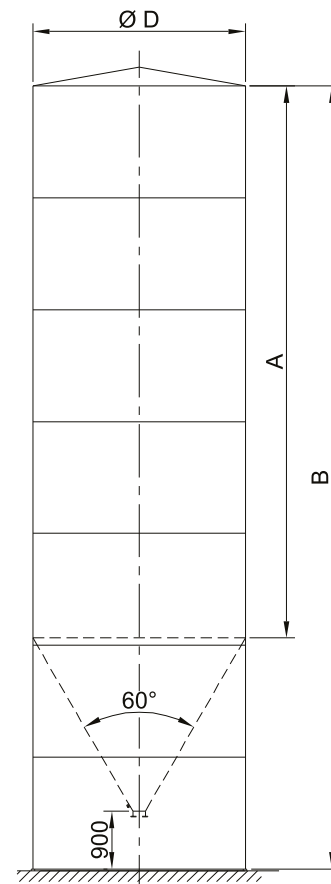

ØD	m ³	A (mm)	B (mm)
Ø4200	122	7,600	12,000
Ø4200	150	9,600	14,000
Ø4200	177	11,600	16,000
Ø4200	205	13,600	18,000
Ø4200	232	15,600	20,000
Ø4200	260	17,600	22,000

FEATURES:

- » Special alloyed Aluminium or SST-304 material option,
- » Opportunity to choose size-volume in special dimensions according to the business area,
- » The calculation in accordance with the Earthquake Code
- » Silo Filling Pipe and Sensor Flanges,
- » Manhole and air discharge chimneys on the Silo Roof
- » The conical discharge angle of 600-900, according to raw material flow characteristics

ITS ADVANTAGES

- » Double compartment silos; It ensures that various raw materials are stocked in separate compartments.
- » It reduces the risk of foreign matter mixing with the raw material.
- » Long life against corrosion,
- » It saves space in the business, reduces the workload.
- » It reduces the raw material loss-leakage rate.
- » Easy and fast installation

Silos are used to store commercially available plastic raw materials. A double chamber silo is a standard silo that is split into two using an additional discharge hopper. The size of the individual silo rooms depends on the capacity of the silo trucks.

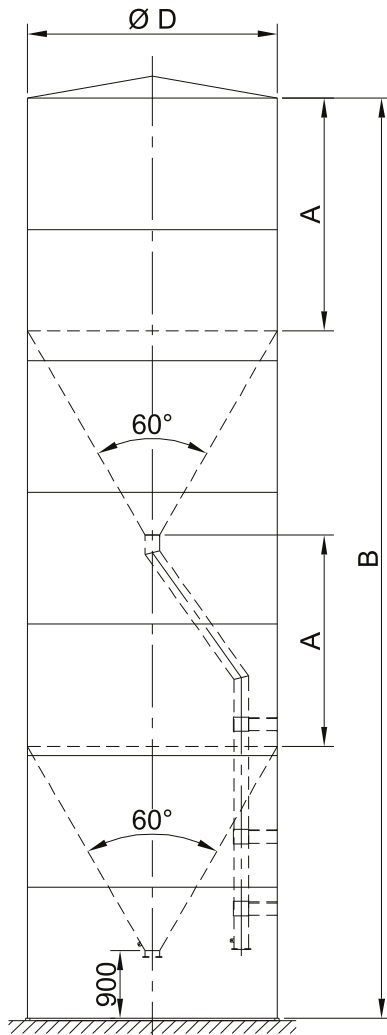

ØD	m ³	A (mm)	B (mm)
Ø3000	2x28	3,150	12,000
Ø3000	2x35	4,150	14,000
Ø3000	2x42	5,150	16,000
Ø3000	2x56	6,150	18,000

ØD	m ³	A (mm)	B (mm)
Ø3500	2x45	3,710	14,000
Ø3500	2x55	4,710	16,000
Ø3500	2x65	5,710	18,000
Ø3500	2x75	6,710	20,000

ØD	m ³	A (mm)	B (mm)
Ø3820	2x52	3,430	14,000
Ø3820	2x63	4,430	16,000
Ø3820	2x75	5,430	18,000
Ø3820	2x86	6,430	20,000

ØD	m ³	A (mm)	B (mm)
Ø4200	2x74	4,100	16,000
Ø4200	2x87	4,100	18,000
Ø4200	2x101	6,100	20,000
Ø4200	2x115	7,100	22,000
Ø4200	2x129	8,100	24,000

FEATURES:

- » Special Alloy Aluminium or Stainless-Steel material
- » Discharge angle according to raw material feature
- » Instantly tracking raw material stocks
- » Long-lasting structure against corrosion
- » Design suitable for food and work safety
- » Installation of independent panels is easily done
- » Wide product range.

ITS ADVANTAGES

- » Reduced shipping costs for large volume silos
- » Eliminates the cost of stocking in the production area.
- » It prevents the raw material from being adversely affected by weather conditions.
- » When applied together with the central loading system, it prevents unnecessary raw material movement within the enterprise.
- » It reduces the risk of foreign matter mixing with the raw material.
- » It provides the possibility of direct shipment of raw materials

It allows the use of raw materials following their purpose at the point where high-capacity raw material stock volume is needed. Aluminium Panel (modules) Silos are used for logistical convenience. Silos are preferred from > Q4200 mm.

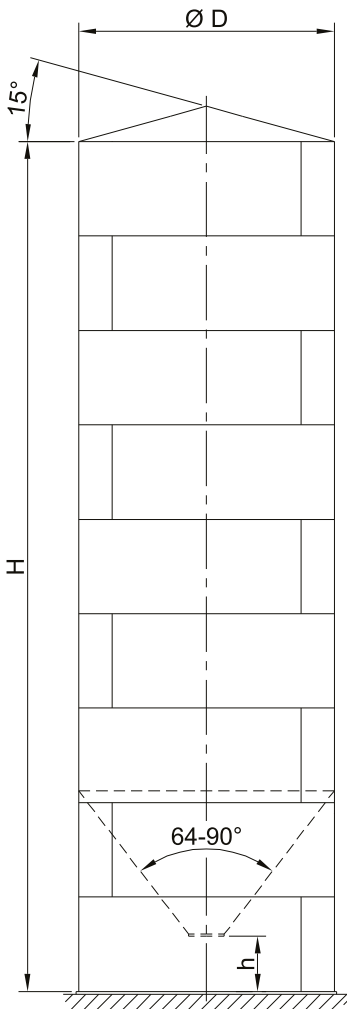

PANEL (MODULAR) ALUMINIUM SILO					
$\varnothing D$	Volume m ³ ($\alpha 64^\circ$)	Volume m ³ ($\alpha 90^\circ$)	Cylindrical Height (H)	Conical Output	h
$\varnothing 5500$	383 m ³	415 m ³	20,000	DN250	1000
$\varnothing 5500$	430 m ³	462 m ³	22,000	DN250	1000
$\varnothing 5500$	478 m ³	509 m ³	24,000	DN250	1000
$\varnothing 5500$	526 m ³	556 m ³	26,000	DN250	1000



FEATURES:

- » Special Alloy Aluminium or Stainless-Steel material
- » Welded joint
- » Suitable for platform mounting
- » Instantly tracking raw material stocks
- » Conical angle according to raw material property
- » Long life against corrosion
- » Design suitable for food and work safety

ITS ADVANTAGES

- » Eliminates costly storage in the production area.
- » It prevents the raw material from being adversely affected by weather conditions.
- » When applied together with the central loading system, it prevents unnecessary raw material movement within the enterprise.
- » It reduces the risk of foreign matter mixing with the raw material.
- » It provides the possibility of direct delivery of raw materials to the machines.

Loading Silos are ideal for stocking plastic raw materials in the form of granules, powders, and flakes and for transferring them to containers or bulk trailer units. The need for loading blinds that arise during this transfer can be met by us.

ØD	m ³	A (mm)	B (mm)
Ø2865	36	4,800	5,300
Ø2865	49	6,800	7,300
Ø2865	62	8,800	9,300
Ø2865	75	10,800	11,300
Ø2865	88	12,800	13,300
Ø2865	100	14,800	15,300
Ø2865	113	16,800	17,300

ØD	m ³	A (mm)	B (mm)
Ø3500	50	4,200	4,700
Ø3500	69	6,200	6,700
Ø3500	88	8,200	8,700
Ø3500	107	10,200	10,700
Ø3500	127	12,200	12,700
Ø3500	146	14,200	14,700
Ø3500	165	16,200	16,700
Ø3500	184	18,200	18,700

ØD	m ³	A (mm)	B (mm)
Ø3820	81	6,000	6,500
Ø3820	104	8,000	8,500
Ø3820	127	10,000	10,500
Ø3820	150	12,000	12,500
Ø3820	173	14,000	14,500
Ø3820	196	16,000	16,500
Ø3820	219	18,000	18,500

ØD	m ³	A (mm)	B (mm)
Ø4200	122	7,600	8,100
Ø4200	150	9,600	10,100
Ø4200	177	11,600	12,100
Ø4200	205	13,600	14,100
Ø4200	232	15,600	16,100
Ø4200	260	17,600	18,100

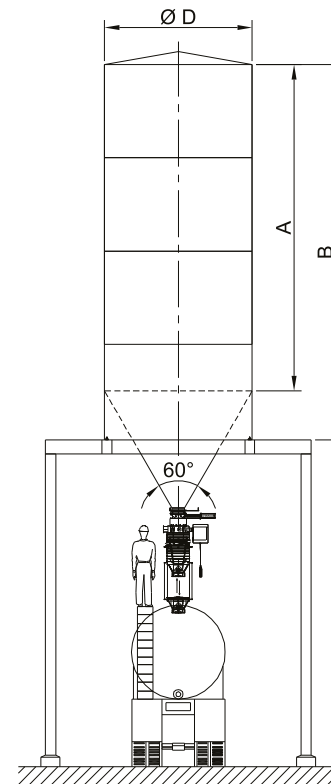

TELESCOPIC LOADING BELLOW (ELECTRICAL MOTORS)

t-max

HOW DOES IT WORK?

- » The system basically works with the principle of trapping the dust generated during the pouring of the powder or granular plastic material through a bellows that can be shortened and lengthened in this bellows assembly. While the material flows down with its own weight from the closed environment, the dust formed is pulled upwards by vacuum.

ADVANTAGES

- » Easy to use
- » Lossless product filling
- » Safe working environment
- » A dust-free ambient air
- » Model option for different applications
- » Sensors preventing raw material from overflowing
- » Automatic pull-up feature when the raw material loading process is finished

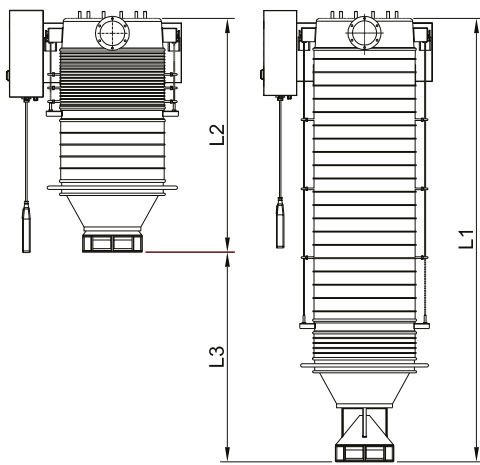

TELESCOPIC LOADING: Prevents the spread of dust and particles that arise during the filling of raw materials into bulk trailer units or containers to the operating environment and the environment. In addition, it prevents product loss and ensures that the filling operation is completed quickly and safely. Our wide product range in this field offers solutions for all sizes thanks to its telescopic design.

No	L1	L2	L3	kW
1	700	225	475	0,55
2	1000	450	550	0,55
3	1300	675	625	0,55
4	1600	900	700	0,55
5	1900	1125	775	0,55
6	2200	1350	850	0,55
7	2500	1575	925	0,55
8	2800	1800	1000	0,55
9	3100	2025	1075	0,55
10	3400	2250	1150	0,55
11	3700	2475	1225	0,55
12	4000	2700	1300	0,55
13	4300	2925	1375	0,55
14	4600	3150	1450	0,55

MIXING SILO (with legs):

The raw material is continuously collected from the conical with the vertical mixing helix and transported upwards to the roof of the silo using the spiral pipe to ensure homogeneous mixing.

ØD	m ³	H (mm)	H1 (mm)	H2 (mm)	n
Ø1250	1,5	1000	2500	3500	3
Ø1250	3	2000	3500	4500	3

ØD	m ³	H (mm)	H1 (mm)	H2 (mm)	n
Ø1910	7	2000	4000	5300	3
Ø1910	10	3000	5000	6300	3
Ø1910	13	4000	6000	7300	3

ØD	m ³	H (mm)	H1 (mm)	H2 (mm)	n
Ø2400	12	2000	4500	5850	4
Ø2400	16	3000	5500	6850	4
Ø2400	21	4000	6500	7850	4

MIXING SILO (with bottom):

The raw material is continuously collected from the conical with the vertical mixing helix and transported upwards to the roof of the silo using the spiral pipe to ensure homogeneous mixing.

ØD	m ³	H (mm)	H1 (mm)	H2 (mm)
Ø2400	21	4000	6500	7850
Ø2400	25	5000	7500	8850
Ø2400	29	6000	8500	9850
Ø2400	33	7000	9500	10850
Ø2400	37	8000	10500	11850

ØD	m ³	H (mm)	H1 (mm)	H2 (mm)
Ø2865	36	4800	8000	9500
Ø2865	49	6800	10000	11500
Ø2865	62	8800	12000	13500
Ø2865	75	10800	14000	15500

BLENDING SILO (central pipe type) - GRAVITY MIXER

The pipe placed in the middle of the silo has different entrances. Due to the special material intake areas, the product flows from different areas by taking advantage of the gravitational force and a homogeneous mixture is provided.

Inlet ports opened in different geometries according to the raw material in the pipes create different flow rates. In this way, it allows the raw material to be mixed homogeneously.

ØD	m ³	H (mm)	ØD	m ³	H (mm)
Ø3000	58	12500	Ø3500	75	12500
Ø3000	76	15000	Ø3500	99	15000
Ø3000	94	17500	Ø3500	123	17500
Ø3000	112	20000	Ø3500	147	20000

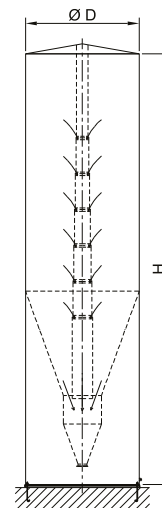
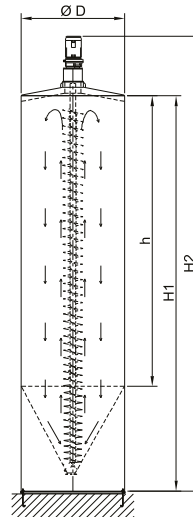
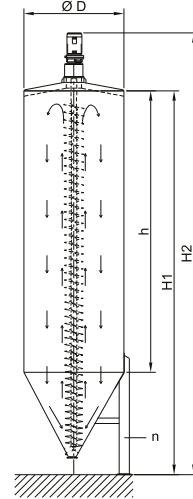

Silo Connection Ring



Basic Silo Study



Silo Fixing Footings



Silo Anchor Assembly



Suction Box



Silo Loading and Transfer lines



Climbing Ladder



Passageways



Filling Elbows

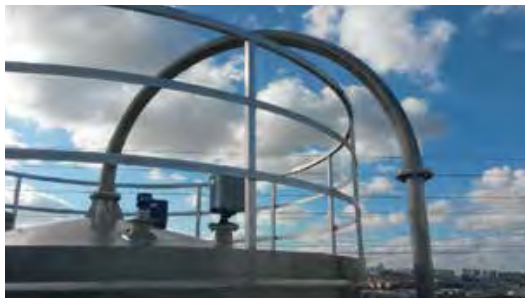

Wear Resistant Elbows



Filling Lines



Filter Systems



Pipe Couplings



Raw Material Conveying Lines

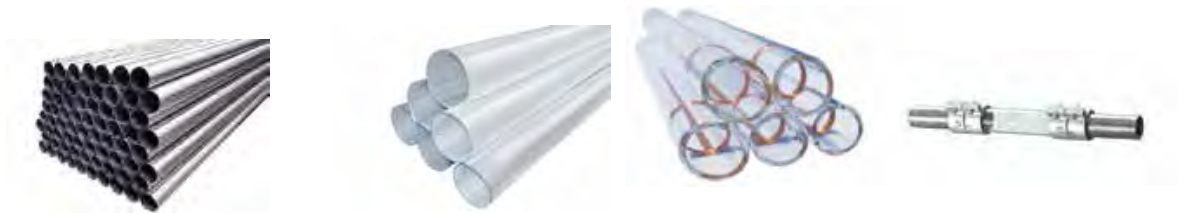

Stainless Steel Elbows (Anti-Wear)



Glass Elbows



Wear Resistant Elbow



Stainless Aluminium 'Y' and 'T' Parts



Glass 'Y' Part



Stainless and Aluminium Reducer



Distribution Stations



Raw Material Conveying Lines





SILO RAW MATERIAL LEVEL CONTROL AND TRACEABLE TOUCH PANELS

FEATURES:

- » Standard silo measuring and control panels (control up to 4-6-8-10 silos)
- » Advanced screen providing the tracking of raw materials
- » Various screen sizes - (3.5, 5.7, and 10 inches)
- » Audible and light warning
- » Access to enterprise database via Ethernet Port
- » Remote access via PC interface program
- » ERP Integration
- » Infrastructure of Industry 4.0 appropriate software
- » Full compatibility with bulk trailer, bag cutting, or container units
- » Error prevention with RFID in silo filling lines (option)
- » POKA-YOKE (Failure Prevention) safety mechanical connection.



SENSOR TECHNOLOGY:

We can use the measurement values obtained by the sensor in different ways. We have various program and analysis device solutions, from displaying values on the screen to using them in complex process analysis via Ethernet to transmitting measurement values via a radio link. We use level sensors with radar, Loadcell, or YO-YO technique.



MINIMUM AND MAXIMUM LEVEL SENSORS

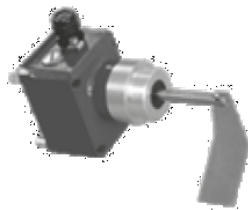

Vibrating Level Sensor

Leaf-type Level Sensor

RADAR TYPE RAW MATERIAL LEVEL SENSOR

FEATURES:

- » Instant or continuous measurement
- » Ease of parameter entry via the hand terminals
- » With non-contact measurement technique; no wear and no maintenance
- » It is not affected by external factors
- » Easy and effortless calibration.

WEIGHT MEASUREMENT SYSTEM

The raw materials in the silos enable weighing using load cells.



ROTARY VALVES (airlock)



SILO TOP FILTERS



and more



CLAMP



MANUAL CLAMP



PINCH VALVE



PRESSURE RELIEF VALVE



MANHOLE VALVE



SILO BOTTOM MAGNET



BIN ACTIVATOR



DIVERTER

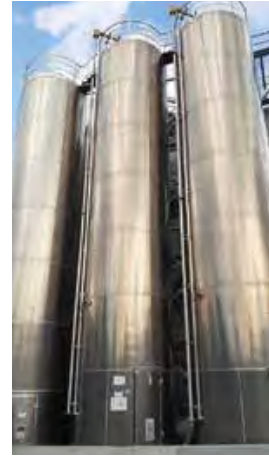

MODULAR SILOS





FEATURES:

- » Complete "deep-dip galvanization" or "SST-304 material" option
- » Modules design
- » Different size options: 2000 x 2000, 2500 x 2500, 3000 x 3000 mm
- » Delivery is made with many options included.
- » Pipe for filling
- » Ports for level sensor
- » Manhole and air discharge chimney on the roof of the silo
- » Ladder and roof railing are supplied optionally.
- » Conical discharge angle of 600 or 900



COMPACT PACKAGING

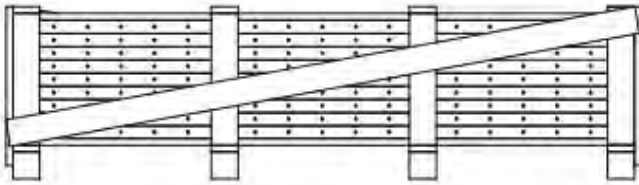

The effective use of spaces in today's businesses is gaining more and more importance day by day. For this purpose, T-MAX modular silos will bring optimum raw material stocking flexibility to your business. The place and areas occupied by the raw materials will help to bring it into production. In this way, it will contribute to the increase of the added value of the occupied areas. With its wide product range, we offer silo options with a suitable capacity for every business.



ITS ADVANTAGES

- » Long life against corrosion
- » Easy and fast installation
- » Static and dynamic calculation report in accordance with earthquake regulations
- » Possibility to increase the volume thanks to the modular structure
- » Low shipping cost with compact package size
- » Less space occupation, more stocking volume thanks to its square structure
- » Raw material, time, and labor savings thanks to direct filling from the bulk trailer or in-line container or tanker.

Angled Roof

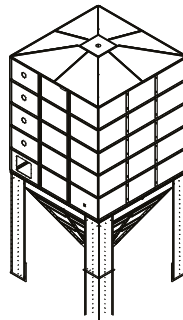

Flat Roof

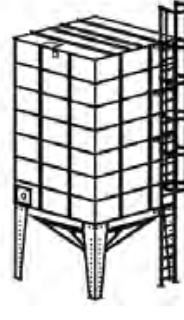

Stairs and Railing

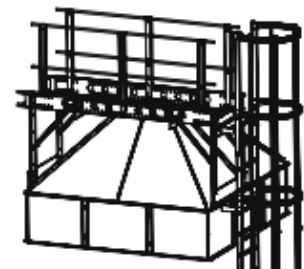

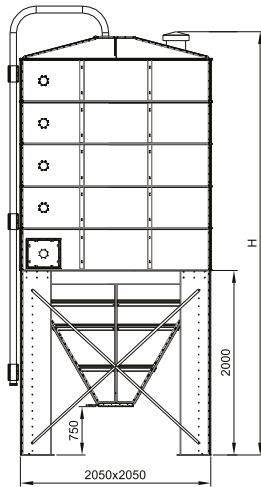

MODULAR SILO 2050x2050			
Measurement (m)	Height - H (m)	Volume (m ³)	Bulk Density (650 kg/m ³)
2050	4,44	10,59	6,88
2050	5,07	12,98	8,44
2050	5,7	15,37	9,99
2050	6,33	17,76	11,54
2050	6,96	20,15	13,10
2050	7,59	22,54	14,65
2050	8,22	24,93	16,20
2050	8,85	27,32	17,76
2050	9,48	29,71	19,31
2050	10,11	32,10	20,87
2050	10,74	34,49	22,42
2050	11,37	36,88	23,97

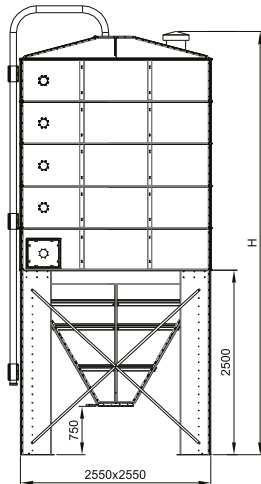

MODULAR SILO 2550x2550			
Measurement (m)	Height - H (m)	Volume (m ³)	Bulk Density (650 kg/m ³)
2550	4,94	16,20	10,53
2550	5,57	19,98	12,99
2550	6,2	23,76	15,44
2550	6,83	27,54	17,90
2550	7,46	31,32	20,36
2550	8,09	35,10	22,82
2550	8,72	38,88	25,27
2550	9,35	42,66	27,73
2550	9,98	46,44	30,19
2550	10,61	50,22	32,64
2550	11,61	54,00	35,10

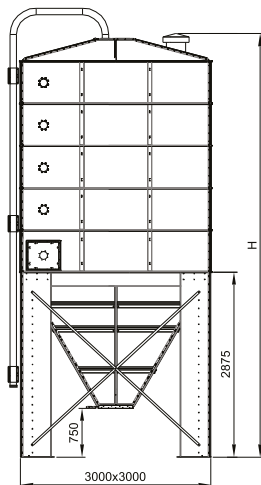

MODULAR SILO 3000x3000			
Measurement (m)	Height - H (m)	Volume (m ³)	Bulk Density (650 kg/m ³)
3000	5,32	23,87	15,52
3000	5,95	29,16	18,95
3000	6,58	34,45	22,39
3000	7,21	39,74	25,83
3000	7,84	45,03	29,27
3000	8,47	50,32	32,71
3000	9,1	55,61	36,15
3000	9,73	60,90	39,59
3000	10,36	66,19	43,02
3000	10,99	71,48	46,46





**ECO EMPTYING STATION
FOR OCTABIN AND BIG BAG**





THE PROBLEM

- » The discharging of octabins and Big Bags through suction pipers is often difficult and not always practical. The conveying is interrupted too often and leads to production disruptions. The films bag is sucked in often or the material does not flow continuously, which is particularly problematic at the end of the discharging process. Often an operator has to guide the suction pipe by hand for a longer period of time in order to discharge a bulk bag.



THE SOLUTION

- » OKTOMAT® Emptying stations
The OKTOMAT® uses a vibrating suction head instead of the suction pipe and the automatic bag tightening mechanism pulls the foil inlet or Big Bag upwards. The suction head floats and vibrates in the material and breaks up lumps. The loosened material flows towards the middle and is continuously sucked.

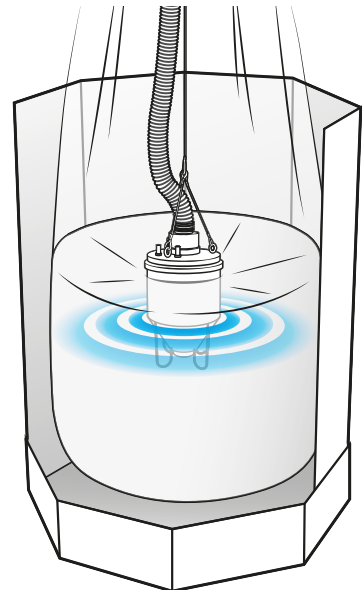

Automatic bag tightening via pneumatic cylinder

Automatic suction head follow-up with sinking filling level



1-During the suction process, the flexible bulk bag wall is pulled up and inwards via the automatic bag tightening system.

2-As a result, the bag tightens and the bulk material in the border area flows to the central suction point.

3-At the end of the discharging process the almost empty bulk bag is automatically lifted up from the bottom enabling a complete material discharging.

System components



Base frames



Controls



Vibrating suction heads



Foil / Big Bag tighteners

The two OKTOMAT series (SOS and ECO) use components from the OKTOMAT system in different combinations according to the modular principle. This allows the optimum emptying station to be configured for almost any application.



Just pallet jack will do

- » Simply use a pallet jack to move the bulk bags, clamp the foil and the suction will follow without supervision and risk of interruption. The bulk bags will be completely emptied.



OKTOMAT discharging stations are already suitable for most applications in their basic configuration. However, there are special materials whose characteristic properties must be taken into account when discharging and conveying.

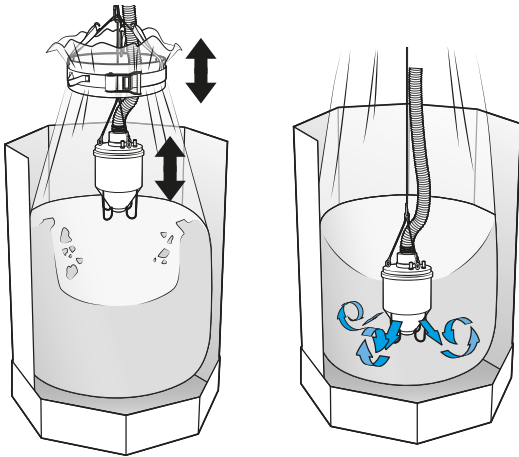

Oscillating suction head and bulk bag tightener

Fluidization

Material-related solutions

- » For every requirement there are appropriate equipments for the configuration of the optimal discharge station.
- » **Oscillating suction head**
Prevents the suction head from going down. Optimum material flow.
- » **Oscillating bulk bag tightener**
Brings bridged material and remaining edge areas to collapse.
- » **Special suction head**
Different distribution of vibration in the granules, approved materials for the bulk solids, ATEX-compliant, etc.
- » **Fluidization**
The material is fluidized additionally, loosening is achieved by compressed air nozzles.

Typical bulk solids that can be discharged easily with OKTOMAT



activated carbon powder



medical cover caps



cut long glass fibre



mixed herbs



foil punching grid



salt

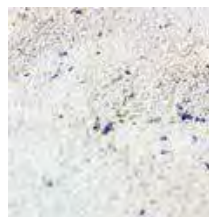

powder free-flowing



flat foil grinding material



hot-melt adhesives



grinding material from shredder



agglomerat



breadcrumbs



glass fibre sticks



pellets virgin material



rubber granulate



	SOS	SOS INOX	SOS Classic
	SOS series		
	Automatic controlled lifting and lowering of the suction head for optimum suction conditions in the bulk bag Oscillation of the foil / Big Bag tightener as a flow aid for the bulk material in border areas to achieve a max. emptying capacity		
Range	Bag tightening range 1000 mm	Bag tightening range 1000 mm	Bag tightening range 1000/1500 mm
Type	Pedestal version	Pedestal version	Portal version
Tension force	Bag tightening force 1500 N	Bag tightening force 1500 N	Bag tightening force 2400 N
Control	SOS-control	SOS-control	SOS-control
Configuration	Full equipment	Full equipment	Full equipment
Functions	<ul style="list-style-type: none"> ■ Automatic complete emptying / automatic bag tightener ■ Oscillating suction head system ■ Oscillating foil / Big Bag tightener system ■ Pipe emptying suction (conveying line) ■ Residual discharge time display ■ Empty signal via LED light and potential-free contact ■ Automatic changeover to the next OKTOMAT® 	<ul style="list-style-type: none"> ■ Automatic complete emptying / automatic bag tightener ■ Oscillating suction head system ■ Oscillating foil / Big Bag tightener system ■ Pipe emptying suction (conveying line) ■ Residual discharge time display ■ Empty signal via LED light and potential-free contact ■ Automatic changeover to the next OKTOMAT® 	<ul style="list-style-type: none"> ■ Automatic complete emptying / automatic bag tightener ■ Oscillating suction head system ■ Oscillating foil / Big Bag tightener system ■ Pipe emptying suction (conveying line) ■ Residual discharge time display ■ Empty signal via LED light and potential-free contact ■ Automatic changeover to the next OKTOMAT®
Placement	Especially space-saving in width	Especially space-saving in width	Especially space-saving in depth, installation on hall wall, several stations next to each other
Operation	Operation sideways	Operation sideways	Operation from the front
Application	Suitable for almost all tasks	Suitable for almost all tasks, additional corrosion protection	Regrind, punch scrap waste, almost all applications

FOR ALL BULK BAGS WITH FOIL INLET OR LOOPS

t-max



	SOS	SOS INOX	SOS Classic
	SOS series		
	Automatic controlled lifting and lowering of the suction head for optimum suction conditions in the bulk bag Oscillation of the foil / Big Bag tightener as a flow aid for the bulk material in border areas to achieve a max. emptying capacity		
Range	Bag tightening range 1000 mm	Bag tightening range 1000 mm	Bag tightening range 1000/1500 mm
Type	Pedestal version	Pedestal version	Portal version
Tension force	Bag tightening force 1500 N	Bag tightening force 1500 N	Bag tightening force 2400 N
Control	SOS-control	SOS-control	SOS-control
Configuration	Full equipment	Full equipment	Full equipment
Functions	<ul style="list-style-type: none"> ■ Automatic complete emptying / automatic bag tightener ■ Oscillating suction head system ■ Oscillating foil / Big Bag tightener system ■ Pipe emptying suction (conveying line) ■ Residual discharge time display ■ Empty signal via LED light and potential-free contact ■ Automatic changeover to the next OKTOMAT® 	<ul style="list-style-type: none"> ■ Automatic complete emptying / automatic bag tightener ■ Oscillating suction head system ■ Oscillating foil / Big Bag tightener system ■ Pipe emptying suction (conveying line) ■ Residual discharge time display ■ Empty signal via LED light and potential-free contact ■ Automatic changeover to the next OKTOMAT® 	<ul style="list-style-type: none"> ■ Automatic complete emptying / automatic bag tightener ■ Oscillating suction head syst ■ Oscillating foil / Big Bag tight system ■ Pipe emptying suction (conveying line) ■ Residual dischar ■ Empty signal via LED light and potential-free contact ■ Automatic changeover to the next OKTOMAT®
Placement	Especially space-saving in width	Especially space-saving in width	Especially space-saving in depth, installation on hall wall, several stations next to each other
Operation	Operation sideways	Operation sideways	Operation from the front
Application	Suitable for almost all tasks	Suitable for almost all tasks, additional corrosion protection	Regrind, punch scrap waste, almost all applications

For all free-flowing, up to "difficult" materials

The OKTOMAT SOS series is able to empty also problematic materials:

- » Regrind
- » Free-flowing powders
- » Bridge-forming granules such as TPE / Soft PVC
- » Bridge building agglomerates or similar
- » Food / salts etc.



Suction head oscillating system

- » The suction head enters vibrating into the material, is pulled up again in a time-controlled manner (the resulting sinkhole in the material fills up) is then lowered back onto the surface and the procedure starts again. The oscillation stroke, lifting force and sequence of short or long strokes are individually adjustable.

Foil / Big Bag tightener Oscillating system

- » In case of very bridging materials, a non-slip wall may occur during the suction process. By repeated lowering and lifting of the foil / Big Bag tightener during suction, the material wall will be loosened, thus enabling the material to flow towards the suction point.

Maximum functionality

- » The OKTOMAT SOS series is already equipped with the most important functions as standard.



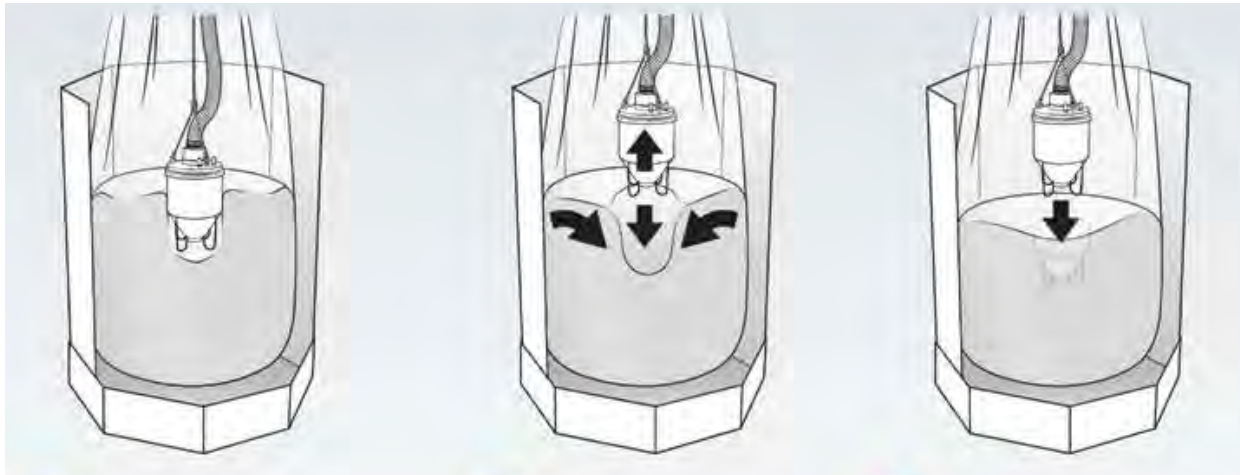

1-During suction, a cavity may result in the suction zone underneath the suction head.

2-The suction head oscillation system raises the suction head. The resulting sinkhole fills up again.

3-The system lowers the suction head back to the surface and makes it sink down timecontrolled.

Oscillating system for foil / Big Bag tightener

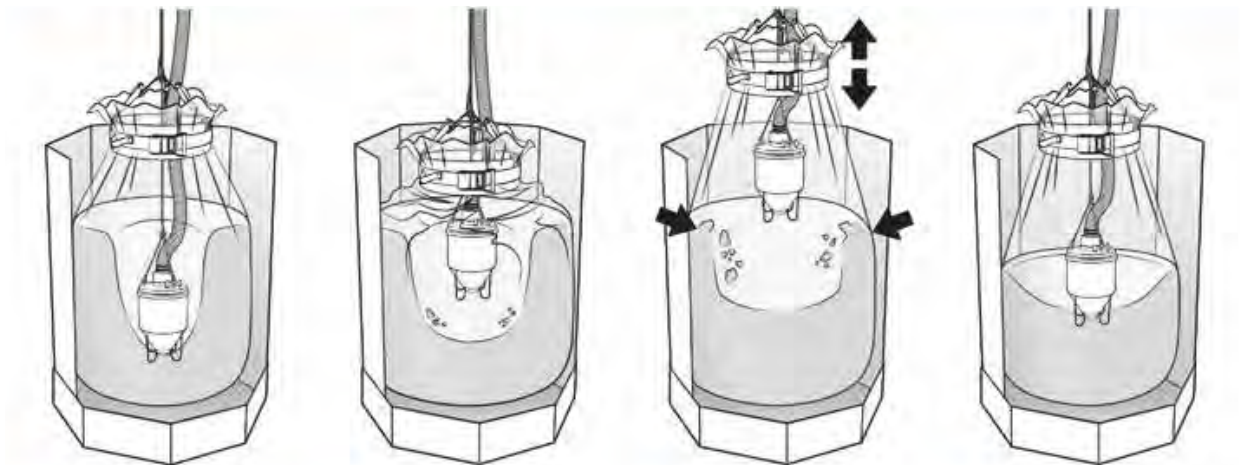

1-The border areas do not slip. A deep sinkhole is formed.

2- The oscillation system lowers the foil / Big Bag tightener towards the bulk material surface and the material under pressure in border area will be released.

3-The suction head is raised and the oscillating system pulls the foil wall upwards. The constricting container wall presses the material walls into the middle and causes them to collapse.

4-The suction head is lowered again and can suck away more material.

Big Bag

Bags with loops

Octabin

Bags with foil inliner

Particularly space-saving in width

Fully equipped

Suitable for almost all tasks

- easy to operate
- unmanned operation
- minimal operating costs
- low maintenance
- robust and durable



STANDARD EQUIPMENT

- » Pedestal version made of steel, powder-coated
- » 8-fold height adjustable
- » Foil / Big Bag tightener made of stainless steel, 600 mm for foil inliners and Big Bag
- » Automatic complete emptying / automatic bag tightener
- » Suction head type S-38 / S-45 / S-50
- » conveying line 38 / 45 / 50 mm
- » Suction head oscillating system
- » Foil / Big Bag tightener oscillating system
- » Tension force 1500 N
- » SOS control
 - Oscillation
 - Empty suction function (conveying line)
 - Residual discharge time display
 - Empty signal via LED light and potential-free contact
 - Automatic changeover to the next OKTOMAT (control part)

MATERIALS

Level of difficulty

free-flowing	Materials
poorly flowable	Materials
bridge-forming	Materials

OKTOMAT SOS is ideally suited for the majority of applications. It handles the emptying of free-flowing to bridge-forming materials. For even more difficult tasks, the discharge station can be extended with options.

Materials	Standard	Optional
free-flowing	●	
poorly flowable	●	
bridge-forming	●	
difficult	—	●

Placement

- » Footprint
- » Due to its pedestal form, the OKTOMAT SOS is particularly space-saving in its width.
- » An area of approx. 1200 mm x 1900 mm is recommended.
- » Operation
- » Containers can be transported on the front, left and right to the OKTOMAT.
- » The control unit can be easily operated from the side. A remote control is available as an option.

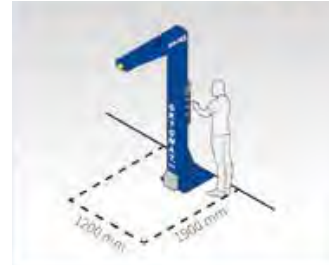

Installation height

- » Installation height
- » The OKTOMAT SOS is 8-fold height-adjustable. The installation height can be selected from 2600 mm - 3650 mm.
- » Container height
- » In order to achieve complete emptying, there must be a minimum distance of 1500 mm between the top edge of the container and the top edge of the discharge station.
- » An increase of 300 mm can be achieved subsequently by means of a base element.

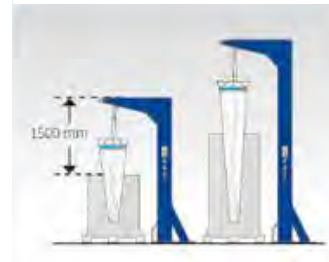

Special versions

- » OKTOMAT SOS INOX
- » OKTOMAT SOS INOX ATEX
- » OKTOMAT SOS partial food version



OPTIONS

- » Double station, automatic switching to next OKTOMAT (pneumatic ball valves)
- » Special suction heads SM / XL / S-80 Clean / XL-80 Clean available with conveying line 38 / 45 / 50 / 60 / 65 / 80 mm
- » AK-version of suction head S-38, S-50 and SM
- » Additional weight for suction head S-38/45/50
- » Pneumatic vibrator for suction head
- » Fluidization by compressed air via nozzles (suction head SM and XL only)
- » Protection cover for containers + foil / Big Bag tightener
- » Special size foil / Big Bag tightener 260 / 400 / 500 mm
- » Remote control with 5 m cable
- » Movable frame on castors, powder-coated
- » Movable frame on castors, stainless steel 1.4301 (AISI 304)
- » Base element to increase height by 300 mm
- » Partial food version for suction head and conveying line
- » OKTOBAG control with intuitive operator guidance and display of all operating states via graphic display

ATEX version



ATEX Zone 22

optionally available in ATEX version partial ATEX zone suction head+conveying line bulk bag tightener complete ATEX version for pedestal control suction head conveying line and bulk bag tightener

Technical specifications

height	2600 - 3650 mm
width / depth	500 mm / 1640 mm
weight / with packaging	170 - 200 kg / 270 - 300 kg
tension force	1500 N
compressed air connection	min. 6 bar. DN 13 mm
electrical connection	- 230 V AC, 50/60 Hz - 110 V AC, 50/60 Hz

Big Bag

Bags with loops

Octabin

Bags with foil inliner

Particularly space-saving in width

Increased tension force for high-density materials

Fully equipped

Suitable for all tasks

Special height available for extra high containers

Special width available for extra wide containers

Suction head oscillating system

Foil / Big Bag tightener oscillating system

- easy to operate
- unmanned operation
- minimal operating costs
- low maintenance
- robust and durable



STANDARD EQUIPMENT

Portal version made of steel, powder-coated
 7-fold height adjustable
 Foil / Big Bag tightener made of stainless steel, 600 mm for foil inliners and Big Bag
 Automatic complete emptying / automatic bag tightener
 Suction head type S-38 / S-45 / S-50
 conveying line 38 / 45 / 50 mm
 Suction head oscillating system
 Foil / Big Bag tightener oscillating system
 Increased tension force 2400 N
 SOS control
 - Oscillation
 - Empty suction function (conveying line)
 - Residual discharge time display
 - Empty signal via LED light and potential-free contact
 - Automatic changeover to the next OKTOMAT (control part)

MATERIALS

Level of difficulty

free-flowing	Materials
poorly flowable	Materials
bridge-forming	Materials

OKTOMAT SOS Classic is ideally suited for the majority of applications. It handles the emptying of free-flowing to bridge-forming materials. For even more difficult tasks, the discharge station can be extended with options.

Materials	Standard	Optional
free-flowing	●	
poorly flowable	●	
bridge-forming	●	
difficult	—	●

Placement

- » Footprint
- » Due to its portal form, the OKTOMAT SOS Classic is particularly space-saving in depth. An area of approx. 1520 mm x 1160 mm is recommended.
- » Operation
- » Containers are transported on the front to the OKTOMAT.
- » The control unit can be operated directly from the front.
- » A remote control is available as an option.

Installation height

- » Installation height
- » The OKTOMAT SOS Classic is 7-fold height-adjustable. The installation height can be selected from 2770 mm - 3670 mm.
- » Container height
- » In order to achieve complete emptying, there must be a minimum distance of 1500 mm between the top edge of the container and the top edge of the discharge station. + 600 mm max. 4270 mm
- » As an option, the maximum construction height can be extended to 4270 mm with an extension (600 mm).
- » Optionally, the OKTOMAT can be extended with an extension (300 mm) (for extra wide containers, max. container width 1500 mm)

OPTIONS

- » Double station, automatic switching to next OKTOMAT (pneumatic ball valves)
- » Special suction heads SM / XL / S-80 Clean / XL-80 Clean available with conveying line 38 / 45 / 50 / 60 / 65 / 80 mm
- » AK-version of suction head S-38, S-50 and SM
- » Additional weight for suction head S-38/45/50
- » Pneumatic vibrator for suction head
- » Fluidization by compressed air via nozzles (suction head SM and XL only)
- » Protection cover for containers + foil / Big Bag tightener
- » Special size foil Big Bag tightener 260 / 400 / 500 mm
- » Remote control with 5 m cable
- » Special height max. 4270 mm (+ 600 mm)
- » Special width 1820 (+ 300 mm)
- » Movable frame on castors, powder coated
- » Partial food version for suction head and conveying line
- » OKTOBAG control with intuitive operator guidance and display of all operating states via graphic display

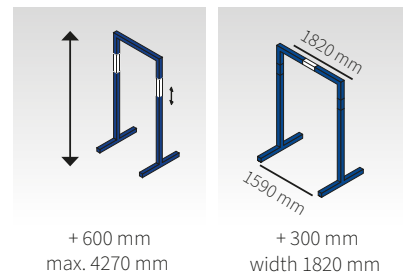
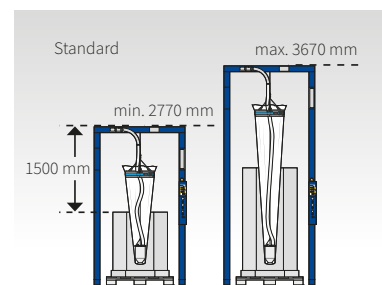
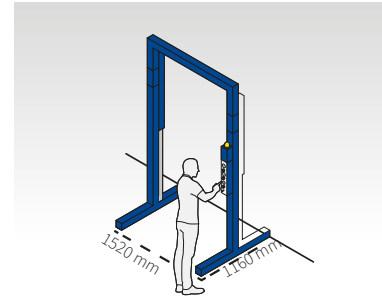

ATEX version



ATEX Zone 22

optionally available in ATEX version partial ATEX zone: suction head + conveying line bulk bag tightener

Technical specifications

height	2770 - 3670 mm
width / depth	1520 mm / 1160 mm
weight / with packaging	160 - 220 kg / 260 - 320 kg
tension force	2400 N
compressed air connection	min. 6 bar. DN 13 mm
electrical connection	- 230 V AC, 50/60 Hz - 110 V AC, 50/60 Hz

Big Bag

Bags with loops

Octabin

Bags with foil inliner

Particularly space-saving in width

Suitable for a wide variety of tasks

Basic configuration

Special heights possible
min. 2500 mm
max. 3900 mm

- easy to operate
- unmanned operation
- minimal operating costs
- low maintenance
- robust and durable



STANDARD EQUIPMENT

- » Pedestal version made of steel, powder-coated
- » 5-fold height adjustable
- » Foil / Big Bag tightener made of stainless steel, 600 mm for foil inliners and Big Bag
- » Automatic complete emptying / automatic bag tightener
- » Suction head type S-38 / S-45 / S-50
- » conveying line 38 / 45 / 50 mm
- » Autom. follow-up of the suction head according to filling level via adjustable counterweight
- » Tension force 1500 N

MATERIALS

Level of difficulty

free-flowing

Materials

poorly flowable

Materials

OKTOMAT ECO is ideally suited for the majority of applications. It handles the emptying of free-flowing to poorly flowable materials.

Materials	Standard	Optional
free-flowing	●	
poorly flowable	●	
bridge-forming	—	●
difficult	—	—

Placement

- » Footprint
 - » Due to its pedestal form, the OKTOMAT ECO is particularly space-saving in width.
 - » The required area to the front depends on the container type used. An area of approx. 1200 mm x 1900 mm is recommended
- » Operation
 - » Containers can be transported on the front, left and right to the OKTOMAT. The control unit can be easily operated from the side.

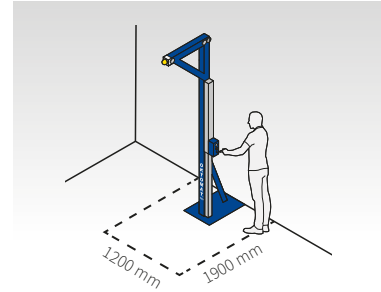

Installation height

- » Installation height
 - » The OKTOMAT ECO is 5-fold height-adjustable.
 - » The standard installation height can be selected from 3000 mm to 3500 mm.
 - » A special height from 3500 mm up to 3900 mm and a space saving height of only 2500 mm - 3000 mm (4 x 125 mm grid) are available as an option.
- » Container height
 - » In order to achieve complete emptying, there must be a minimum distance of 1500 mm between the top edge of the container and the top edge of the discharge station.
 - » An increase of 300 mm can be achieved subsequently by means of a base element.

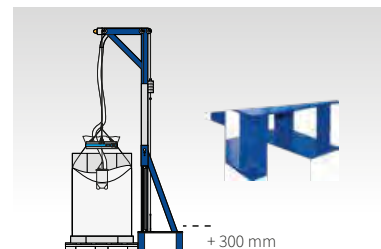
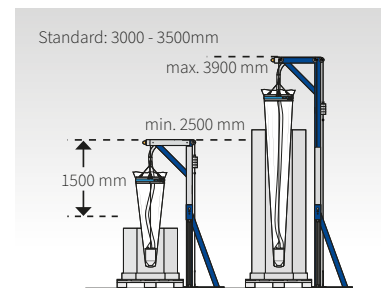

OPTIONS

- » ECO-control for empty signal via LED light and potential-free contact, display of residual discharge time
- » Double station, automatic switching to next OKTOMAT (pneumatic ball valves)
- » Special suction head XL available with conveying line 38 / 45 / 50 / 60 / 65 / 80 mm
- » AK-version of suction head S-38, S-50 and SM
- » Additional weight for suction head S-38/45/50
- » Pneumatic vibrator for suction head
- » Protection cover for containers + foil / Big Bag tightener
- » Special size foil / Big Bag tightener 260 / 400 / 500 mm
- » Movable frame on castors, powder-coated
- » Partial food version for suction head and conveying line
- » Special height: 2500 to 3000 mm
- » Special height: 3500 to 3900 mm
- » Base element to increase height by 300 mm

ATEX version



optionally available in ATEX version partial ATEX zone: suction head + conveying line bulk bag tightener

Technical specifications

height	3000 - 3500 mm
width / depth	500 mm / 1540 mm
weight / with packaging	125 - 145 kg / 225 - 245 kg
tension force	1500 N
compressed air connection	min. 6 bar. DN 13 mm
electrical connection	- 230 V AC, 50/60 Hz - 110 V AC, 50/60 Hz

Big Bag Bags with loops

Octabin Bags with foil inliner

Particularly space-saving in depth

Increased tension force for high-density materials

Basic configuration expandable up to full SOS equipment

Special assembly height for extra high containers

Special width for extra wide containers

- easy to operate
- unmanned operation
- minimal operating costs
- low maintenance
- robust and durable



STANDARD EQUIPMENT

- » Portal version made of steel, powder-coated
- » 7-fold height-adjustable
- » Foil / Big Bag tightener made of stainless steel, 600 mm for foil inliners and Big Bag
- » Automatic complete emptying / automatic bag tightener
- » Suction head type S-38 / S-45 / S-50 conveying line 38 / 45 / 50 mm
- » Autom. follow-up of the suction head according to filling level via adjustable counterweight
- » Increased tension force 2400 N

MATERIALS

Level of difficulty

free-flowing

Materials

poorly flowable

Materials

OKTOMAT ECO is ideally suited for the majority of applications. It handles the emptying of free-flowing to poorly flowable materials. For even more difficult tasks the discharge station can be extended with options.

Materials	Standard	Optional
free-flowing	●	
poorly flowable	●	
bridge-forming	—	●
difficult	—	●

Placement

- » Footprint
 - » Due to its portal form, the OKTOMAT ECO Classic is particularly space-saving in depth.
 - » An area of approx. 1520 mm x 1160 mm is recommended.
- » Operation
 - » Containers are transported on the front to the OKTOMAT.
 - » The control unit can be operated directly from the front.

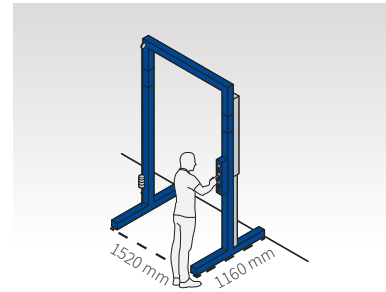

Installation height

- » Installation height
 - » The OKTOMAT ECO Classic is 7-fold height-adjustable. The installation height can be selected from 2770 mm - 3670 mm.
- » Container height
 - » In order to achieve complete emptying, there must be a minimum distance of 1500 mm between the top edge of the container and the top edge of the discharge station.
- » As an option, the maximum construction height can be extended to 4270 mm with an extension (600 mm).
- » A special width of 1820 mm is available (for particularly wide containers, max. container width 1500 mm).

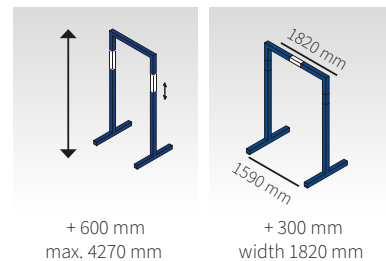
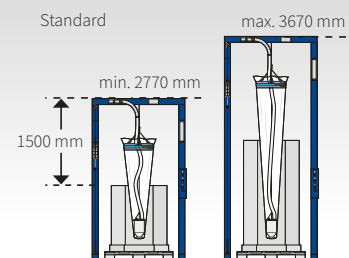

OPTIONS

- » ECO-control for empty signal via LED light and potential-free contact, display of residual discharge time
- » Double station, automatic switching to next OKTOMAT (pneumatic ball valves)
- » Special suction head XL available with conveying line 38 / 45 / 50 / 60 / 65 / 80 mm
- » AK-version of suction head S-38, S-50 and SM
- » Additional weight for suction head S-38/45/50
- » Pneumatic vibrator for suction head
- » Protection cover for containers + foil / Big Bag tightener
- » Special size foil / Big Bag tightener 260 / 400 / 500 mm
- » Special height max. 4270 mm (+ 600 mm)
- » Special width 1820 mm (+ 300 mm)
- » Movable frame on castors, powder-coated
- » Partial foodstuff version for suction head and conveying line
- » Oscillating system suction head
- » Oscillation system foil / Big Bag tightener

ATEX version



ATEX Zone 22

optionally available in ATEX version
 partial ATEX zone: suction head + conveying line
 bulk bag tightener complete ATEX version for portal, suction head, conveying line and bulk bag tightener (ECO/SOS control not available)

Technical specifications

height	2770 - 3670 mm
width / depth	1520 mm / 1160 mm
weight / with packaging	160 - 220 kg / 260 - 320 kg
tension force	2400 N
compressed air connection	min. 6 bar. DN 13 mm
electrical connection	- 230 V AC, 50/60 Hz - 110 V AC, 50/60 Hz

Completely made of stainless steel

OKTOMAT SOS Classic INOX emptying stations are used especially in sensitive production areas with the highest demands.

Oscillating system suction head

Oscillating system bulk bag tightener

Suitable for high-pressure cleaning

- Resistant to aggressive cleaning agents



STANDARD EQUIPMENT

- » Portal version made of stainless steel 1.4301 (AISI 304)
- » 10-fold height-adjustable
- » Suction head S-80 Clean made of stainless steel 1.4571 (AISI 316) with compressed air vibrators available with conveying line 38/50/65/80 mm
- » Big Bag tightener with 4 stainless steel carabiners
- » Automatic complete emptying / automatic bulk bag tightener
- » Discharge aids by means of steplessly adjustable vibrators in the suction head oscillation of the suction head oscillation of the bulk bag tightener
- » Empty suction function (conveying line)
- » Empty signal, potential-free contact
- » OKTOBAG control with intuitive operator guidance and display of all operating states via graphic display

MATERIALS

Level of difficulty

free-flowing	Materials
poorly flowable	Materials
bridge-forming	Materials
difficult	Materials

OKTOMAT SOS Classic INOX masters all materials from free-flowing to the most difficult materials and is used in particularly sensitive production areas with the highest demands.

Materials	Standard	Optional
free-flowing	●	
poorly flowable	●	
bridge-forming	●	
difficult	●	

Control

- » The OKTOBAG control is an extremely comprehensive discharge control and includes
- » Graphic display with intuitive operator guidance
- » Display of all operating states
- » 5 function keys
- » Buttons for automatic operation
- » Button for conveyor unit ON/OFF
- » The entire program sequence can be individually programmed and individual functions can be disabled or enabled. The operating personnel have to take care only of manual or automatic operation.



Status OKTOMAT

actual weight	kg	280
change bag	after	kg 50
immersion time		
lower bag		2.0

Switch-over Option 2

actual weight	ON	OFF
switch-over		

Suction head oscillating

Dive	sec	02
short Lift		01
long Lift		00

Lifting ring oscillating

> lowering bag	min	02
lowering time	sec	05
Function Option 9	ON	OF



Big Bag tightener

- » The ring is suitable for Big Bag with loops. It can be easily converted from low to high containers. Material: stainless steel

Suction head

- » Vibrating suction head to loosen and suck off the bulk material.
- » Material: stainless steel 1.4408/1.4571 (AISI 316), PUR conveying hose.

OPTIONS

- » Double station, automatic switching to next OKTOMAT (pneumatic ball valves)
- » Weighing of the residual material counting down from 150 kg via strain gauge tension element
- » Weighing platform with negative weighing of the entire system
- » Foil bag tightener for foil liners
- » Protection cover for bulk bags + foil / Big Bag tightener
- » Suction head XL-80 Clean of stainless steel 1.4571 (AISI 316) with pneumatic vibrators

ATEX version



Optionally available in ATEX version complete ATEX version including portal and control

Technical specifications

material	1.4301 (AISI 304)
height	2230 - 3730 mm
width / depth	1840 / 1150 mm
weight / with packaging	260 kg / 420 kg
protection type	IP 66 / IP 69 K
compressed air connection	min. 6 bar, max.8 bar, DN 13
electrical connection	- 230 V AC, 50/60 Hz
	- 110 V AC, 50/60 Hz



Pedestal version ECO



Pedestal version SOS



Portal version ECO/SOS



Portal version INOX

Big Bag tightener



Type	Ø Conveying hose	diameter	Vibrator electric	Vibrator pneumatic	ATEX	CLEAN	AK
S-38	38 mm	295 mm	●	○	○	—	○
S-45	45 mm	295 mm	●	○	○	—	—
S-50	50 mm	295 mm	●	○	○	—	○
SM	38 / 45 / 50 / 60 / 65 / 80 mm	295 mm	—	●	○	—	○
XL	38 / 45 / 50 / 60 / 65 / 80 mm	495 mm	●	○	○	—	—
S-80 C	38 / 50 / 65 / 80 mm	250 mm	—	●	●	●	—
XL-80 C	38 / 50 / 65 / 80 mm	450 mm	—	●	●	●	—

● standard ○ optional — not available

Bulk bag tightener



Special sizes and versions

Type	Use	Diameter	Fixation	
Foil / Big Bag tightener	Big Bag + foil	260 mm	lashing strap + carabiner	○
Foil / Big Bag tightener	Big Bag + foil	400 mm	lashing strap + carabiner	○
Foil / Big Bag tightener	Big Bag + foil	600 mm	lashing strap + carabiner	●
Foil tightener	Foil (ATEX Zone)	600 mm	clamping jaws	○
Big Bag tightener	Big Bag	500 mm	carabiner	○

● standard ○ optional

suitable for all OKTOMAT® types



	SOS	SOS Classic	ECO	ECO Classic
only operating panel	—	—	●	●
Control ECO	—	—	○	○
Control SOS	●	●	—	—
Control OKTOBAG®	○	○	—	—
Control OKTOBAG® ATEX	○	—	—	—

● standard ○ optional — not available

ECO control



Control for residual discharge time or for residual discharge time and double station with potential-free contact for empty signal

- adjustable residual discharge time
 - basic control for double station
- Included as standard in SOS control

OKTOMAT ECO suitable for series

OKTOMAT ECO Classic

OKTOBAG control



The OKTOBAG control is an extremely comprehensive discharge control and includes

- Graphic display with intuitive operator guidance
- Display of all operating states
- 5 function keys
- Buttons for automatic operation
- Button for conveyor unit ON/OFF

The entire program sequence can be individually programmed and individual functions can be disabled or enabled.

OKTOMAT SOS suitable for series

OKTOMAT SOS Classic

OKTOBAG control



As soon as a signal is received from the ECO / SOS / OKTOBAG control, the conveying is switched on to the next full container via pneumatic ball valves.

- Ideal for unmanned shifts

suitable for all OKTOMAT types

Remote control



Lifting and lowering of suction head and foil / Big Bag tightener, automatic operation
- 5 m cable

OKTOMAT SOS suitable for series

OKTOMAT SOS Classic

Conveying line emptying

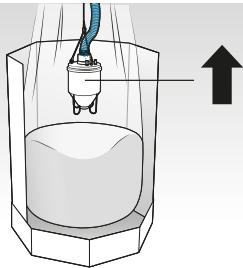

In order to be able to empty the pipeline after each conveying process (e. g. in the case of long rising pipes), the suction head is raised above the bulk material level in the container when a signal is received from a conveyor control system and the pipeline is emptied.

OKTOMAT SOS

OKTOMAT SOS Classic

Fluidization

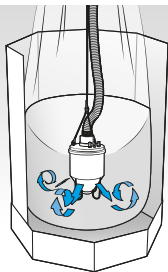

For loosening up dense bulk material, compressed air can be injected to fluidize the material to be sucked off.

available for suction head SM and XL only

separate control with two independent pneumatic circuits

OKTOMAT SOS suitable for series

OKTOMAT SOS Classic

Protection cover



Cover for containers + foil / Big Bag tightener
PVC, transparent with zipper
Ø 1200 mm
Ø 1600 mm

suitable for all OKTOMAT types

Protection cover



The additional weight increases the contact weight of the suction head on the bulk material and thus helps to enter into the bulk material.

Additional weight
- available for suction head S38 / S45 / S50 only
- + 4 kg

suitable for all OKTOMAT types

Protection cover



Movable frame on 4 castors incl. fixing bolts. Suitable for continuous use.
Height: 155 mm (175 mm when fixed)

OKTOMAT SOS

suitable for series
Width 1500 mm
Depth 1400 mm

OKTOMAT ECO

OKTOMAT SECO Classic

suitable for series
Width 1500 mm
Depth 1470 mm

OKTOMAT SOS Classic

Pipe elbows



DN38, DN45 and DN50 (outer diameter)

Standard pipe elbow (stainless steel 1.4301 (AISI 304))
 -Stainless steel pipe elbow (hardened) wear-resistant
 -Glass pipe elbow highly wear-resistant

suitable for all OKTOMAT types

Special height



Extension 600 mm for maximum installation height of 4270 mm

OKTOMAT SECO Classic

suitable for series

OKTOMAT SOS Classic

Special width



Extension 300 mm for maximum portal width of 1820 mm for extra wide containers,
 max. width of container 1500 mm

OKTOMAT SECO Classic

suitable for series

OKTOMAT SOS Classic

Special width



A: Special height: 3500 - 3900 mm (4 x 100 mm steps)
 B: Special height: 2500 - 3000 mm (4 x 125 mm steps)

OKTOMAT ECO

suitable for series

Height increasing base element



Base element to increase height by 300 mm. Mounting on OKTOMAT foot section.

- Height: 300 mm
 - Weight: 64 kg

OKTOMAT SOS

suitable for series

OKTOMAT ECO

Robust and durable Low maintenance

Thousands of OKTOMAT systems are in use worldwide. Most of them work in 3-shift operation under the hardest conditions, e.g. in the plastics and chemical industries.

Low maintenance

OKTOMAT discharging stations are designed for low maintenance and service-friendly. Any necessary spare parts can be changed with just a few steps.

Short payback period

OKTOMAT discharging stations usually amortize after a few months. The exact amortisation period depends on the savings in terms of man-hours in the respective application case and the costs incurred so far due to production disruptions.

After Sales Service

» We do not leave you alone with the HELIOS components but accompany you through the entire process from the selection up to starting up and training of your employees. That is what we understand by partnership. Our staff will be pleased to advise you on the possible applications of our products and to inform you about our latest technical developments - also for possible retrofits.

- » consulting
- » starting up
- » training
- » upgrade
- » maintenance/checking up
- » spare parts supply within 24h



History of a success story

- » OKTOMAT system discharging station wins out worldwide
- » HELIOS was granted an EP and a US patent for a suction device based on a patent application in 1995 in which a floating suction head is used for discharging bulk bags from above instead of the usual suction pipe. The foil bag is automatically pulled upwards via a tensioning device in order to achieve a complete discharging.
- » Following this fundamental idea, further procedural and additional features were developed gradually, such as
 - » Raising the remaining bulk material off the floor
 - » Clamping of the foil bag by means of a tension belt
 - » Oscillation of the suction head while discharging
 - » Fluidization of the bulk material by compressed air via nozzles at the suction head
 - » Clamping and relieving the bulk bag wall while discharging
- » Which were also protected by patent, the "OKTOMAT" system.
- » Depending on the task, various frame types have proven to be particularly advantageous in practice.
- » Since its launch at FAKUMA in 1996, more than 5000 systems have been installed worldwide.



OKTOMAT

- » Robust and durable
- » Unmanned operation
- » Proven in thousands
- » Easy to operate
- » Min. operating costs
- » Suitable for all materials
- » Short payback period

injection molding blow molding extrusion compression molding

- | | | |
|------------------|-----------------------------|-------------------|
| - paper / foil | - logistics | - automotive |
| - PVC processing | - paper finishing | - plug connectors |
| - recycling | - chemistry / raw materials | - packaging |
| - cable | - medical technology | - foil production |
| - optics | - food | |
| - lighting | - raw material handling | |
| - WPC | - technical parts | |



Hopper loaders



TAL- Glass Tube Loading Chamber



TAL-300E
6 Liters



TAL-6U
1,5-12 Liters

Vacuum stations



Vacuum stations

Cantilever arm + vacuum conveyor

available for

- OKTOMAT SOS
- OKTOMAT SOS Classic
- OKTOMAT ECO
- OKTOMAT ECO Classic

local / external assembly

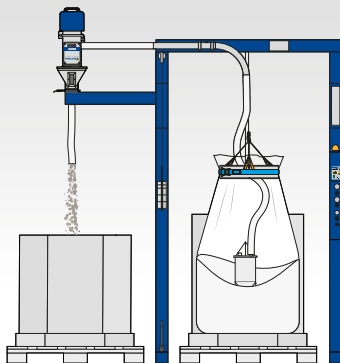

Refilling station

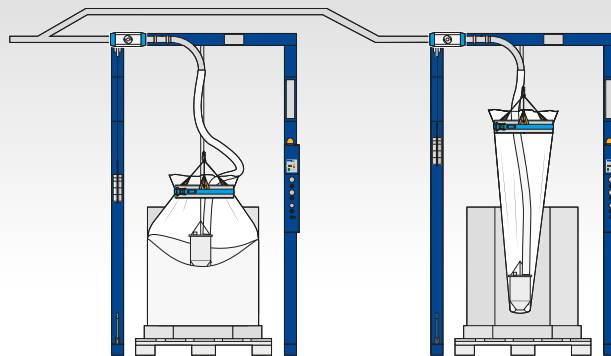

Double station with autom. switchover

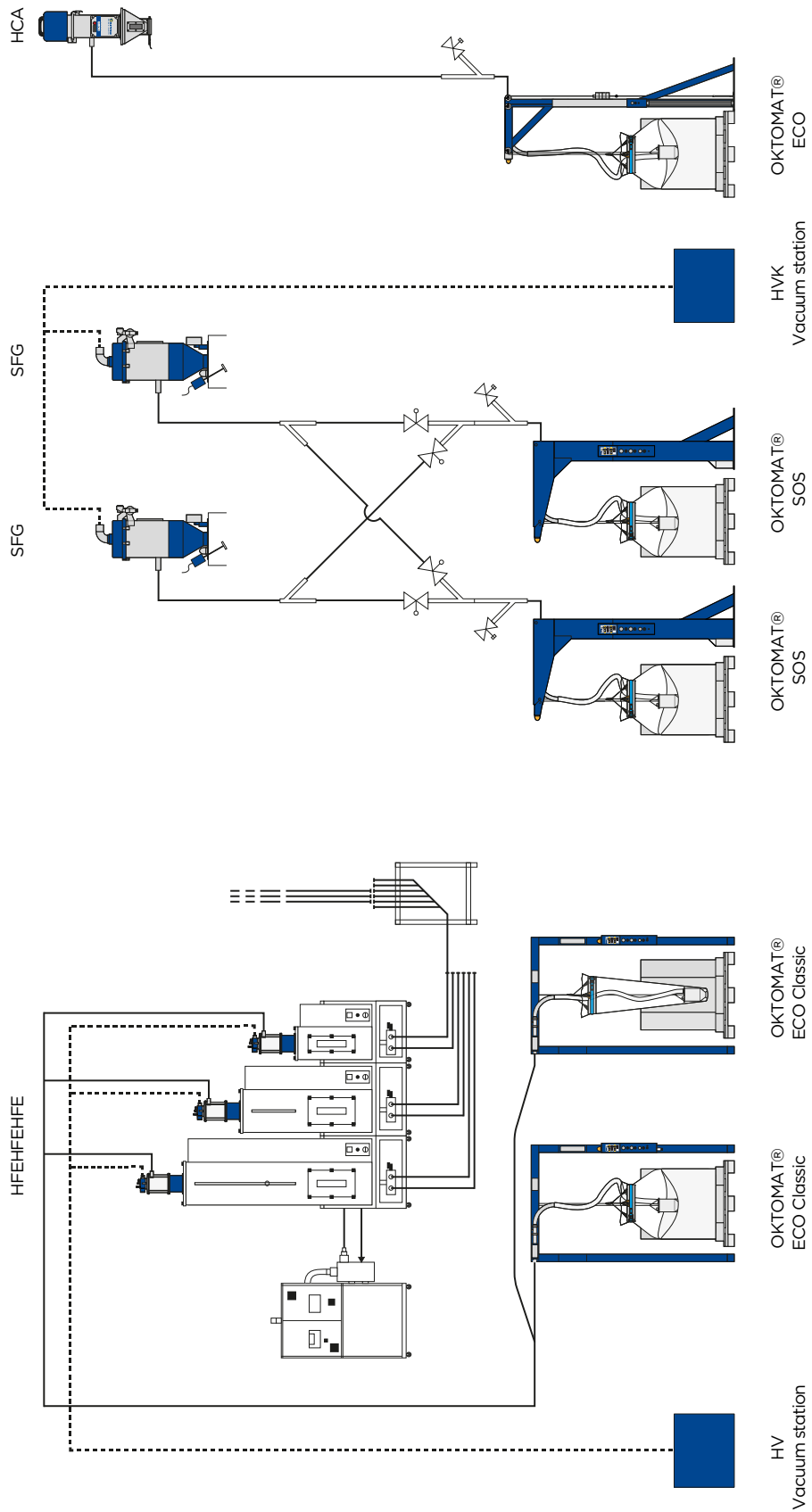



**MULTI MATERIAL FEEDING
AND WEIGHING UNITS**

T-MAX SWH series weighing station vacuum feeding unit is designed for measurable, easy, effortless and precise feeding of multiple or single raw materials to the chamber or big-bags before homogenization, storage or processing to vertical or horizontal mixers.

FEATURES:

- » High operational safety thanks to years of experience and fully developed technology.
- » Elimination of raw material scattering and transportation problems within the business.
- » Automatic feeding to high precision vertical or horizontal mixers, chambers or big-bags.
- » Feeding of many different raw materials with single or multiple lines.
- » Easy and fast cleaning.
- » Measurable mixtures and reports (kg, hour, shift etc.)
- » High weighing and dosing accuracy
- » A quick cleaning with wide cleaning covers.
- » Maximum flexibility for businesses.
- » Production with constant product quality.
- » Quick recipe change.
- » Accurate production coordination with advanced control unit.



FEEDING SYSTEM WITH SINGLE-RAW MATERIAL

- » With the single line system a feeding line carries the products from all product feeding points such as mixer chambers, big bag unloading stations, open or closed silos to the weighing chamber.
- » Measuring and weighing control compensates for different transport points caused by varying distances.
- » This feature improves the stability and accuracy of the unit.

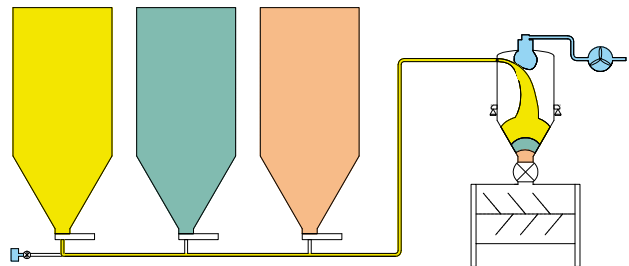

FEEDING SYSTEM WITH MULTI-RAW MATERIALS

- » In the multi-line feeding system, it feeds separately from different raw material points, adhering to the recipe set in the control unit.
- » After reaching the weighed raw material set value from each feeding phase, it continues to feed the other raw material.
- » Thanks to the cleaning function of the unit, it ensures that the weighing precision continues at the highest level by cleaning the line at each raw material pass.
- » The system provides a more flexible working opportunity compared to single-pipe raw material lines.

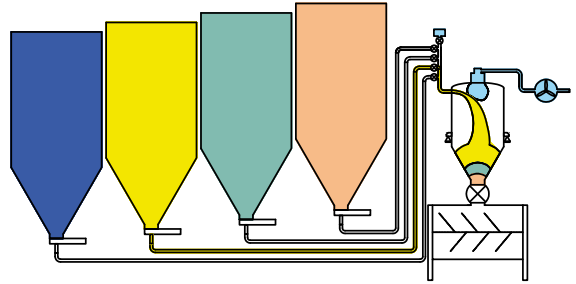

CENTRAL WEIGHING SYSTEM AND ITS CHAMBER

- » A central weighing system and hopper are available for most entry and discharge points.
- » The system is fed by a central vacuum pump.
- » In this way, raw material transitions and line cleaning processes are carried out in an extremely fast and controlled manner.
- » This feature keeps the weighing sensitivity at an extremely high level.
- » It provides for the businesses significant cost, labor, and production advantages with the right recipe by combining the benefits of the vacuum system and the weighing function.

**BIG-BAG STAND
EMPTYING FRAME**



Since 1969 the Extrac division of WAM has been designing and manufacturing many different configurations of bulk bag unloader, also called FIBC unloaders for all types of powders and granular materials. The addition of the new HFF series of models to the range have been designed for optimal high flow rate Bulk Bag Unloading.

FEATURES:

- » Bulk Bag Unloader SBB.C – Half Frame
- » The Half Frame SBB.C Bulk Bag Unloader comes complete with a product storage/discharge hopper and cross lifting frame for holding the FIBC Bulk Bag into the discharged by forklift of overhead crane.
- » Includes a vibrating pan plate and dust collection point to ensure efficient and clean bulk bag unloading.
- » Lockable access hatch for Bag neck tie opening with option for door interlock switch
- » Optional bag massagers available for hard to move materials.
- » Available with bag splitting knives.
- » Bulk Bag Unloaders are available in Carbon steel, Stainless steel 304 and Stainless steel 316.
- » Available in 1,250mm or 1,500mm diameter cones for different sizes bag and holding requirements.
- » Every unit comes with Certified Bulk Bag Lifting Cross with 2000kg SWL.

High Flow Rate FIBC Dischargers SBB-HFF



Big-Bag Discharging Unit suitable for the Forklift Loading. (Model 1-2)



Big-Bag Discharging Unit with Monorail (Model 3)



FEATURES:

- » Bulk Bag Unloader SBB.S- Full Telescopic Frame
- » The Full Frame SBB.S Bulk Bag Unloader provides an effective solution to unloading bulk bags of product in an efficient manner. The Forklift or Crane loads the bag on the lifting cross into the telescopic rack which supports the bag while discharging.
- » Available in Carbon steel, Stainless steel 304 and Stainless steel 316
- » Includes a vibrating pan plate level probe point and dust collection point to ensure efficient and clean bulk bag unloading.
- » Lockable access hatch for Bag neck tie opening with option for door interlock switch
- » Optional bag massagers available for hard to move materials.
- » Available with bag splitting knives.
- » Available in 1,250mm or 1,500mm diameter cones for different sizes bag and holding requirements.
- » Every unit comes with Certified Bulk Bag Lifting Cross with 2000kg SWL.

ADVANTAGES

- » Bulk Bag Unloader SBB.M – Full Monorail Frame and Crane Hoist
- » The Full Frame Monorail and Hoist Frame SBB.M Bulk Bag Unloader does not require the use of a forklift or overhead crane to load bags. The pendant controlled hoist and monorail make the loading and unloading of bags a simple task.
- » Available in Carbon steel, Stainless steel 304 and Stainless steel 316.
- » Includes a vibrating pan plate level probe point and dust collection point to ensure efficient and clean bulk bag unloading.
- » Lockable access hatch for Bag neck tie opening with option for door interlock switch
- » Optional bag massagers available for hard to move materials.
- » Available with bag splitting knives.
- » Available in 1,250mm or 1,500mm diameter cones for different sizes bag and holding requirements.
- » Every unit comes with Certified Bulk Bag Lifting Cross with 2000kg SWL.

Measurement	A	B	C	E	F
SBB. 125.C	1.914	1.400	832	100	1.734
SBB. 150.C	2.490	1.800	1.047	160	1.880

Sizes in mm

Measurement	A max.	B	C	E	F	G
SBB. 125.S	3.960	1.400		130	100	1.734
SBB. 150.S	4.307	1.800	1.047	180	160	1.800

Sizes in mm

Measurement	A	B	C	E	F	G	H	L
SBB. 125.M	4.810	1.400	832	160	1.734	2.150	750	3.765

Sizes in mm

Model 1-2

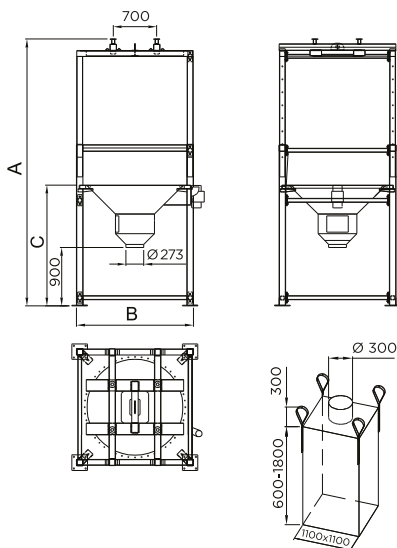

Model 3

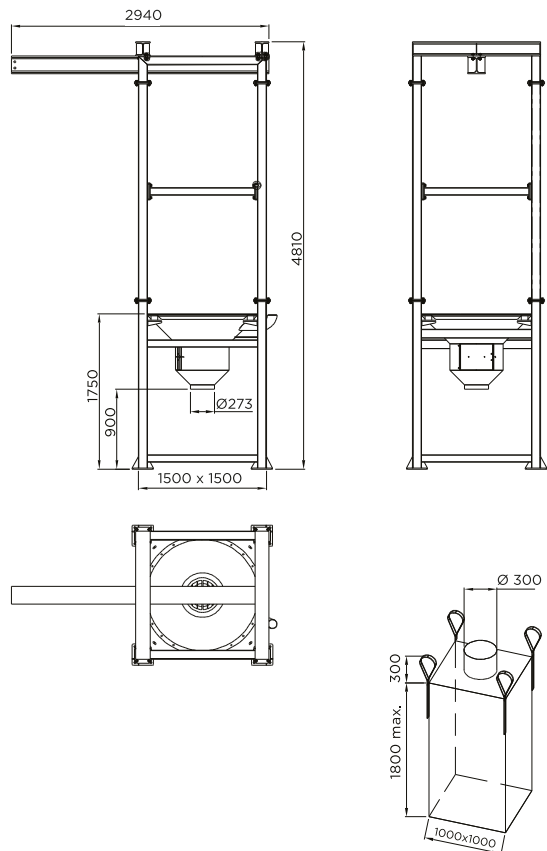



**BAG OPENING AND
EMPTYING MACHINE-BAGOMAX**

BAG OPENING AND EMPTYING MACHINE-BAGOMAX

t-max

FEATURES:

- » With the fully automatic bag emptying machine, granulate bags of 25 kg can be opened and emptied into a receiving bin.
- » The capacity of the machine is between 10 and 15 tons of granules per hour.
- » Emptying is better than 99.98%!
- » It is also possible to transport or drop the empty bags (in) to a bag compactor or baler.
- » The granulate in the receiving bin is transported from the bin by means of a granulate pump into the pneumatic transport system.
- » This system provides a durable and reliable transport to storage silos



FEATURES:

- » Expandability: possibility to Add a bag compacter
- » Add a pallet stacker
- » Implement in complex control system with full process control
- » Flexibility (additional options, executions can be discussed)
- » Robust execution
- » Separated steady movements
- » Electrical lift executes vertical movements
- » Shuttle executes horizontal movements



FEATURES:

- » 25 kg of granule bags, which come in pallets with a fully automatic bag unloading machine, are opened and emptied into the hopper without human touch.
- » The granule discharged into the hopper can be automatically transferred to the desired point by means of a pump.
- » Machine capacity can work up to 15 tons/h for granular raw materials.
- » Hopper discharge conical angle suitable for raw material properties. Easy and fast installation.

ITS ADVANTAGES

- » It is ideal for factories processing raw materials at high capacity.
- » It reduces labor costs.
- » It fully complies with work safety.
- » It empties all the granules in the bag.
- » It reduces the risk of raw materials and escaping of foreign matters.
- » Seamless integration into central systems.
- » Compatibility with existing silos or silo filling units
- » HIGH RATIO OF INVESTMENT.

With its **fully automatic bag opening and unloading machine**, it can open 25 kg of plastic, paper, and jute bags and automatically empty them into a collection hopper. Bags filled with raw materials can be placed in the machine automatically or manually with their pallets. The capacity of the machine can run up to 15 tons/hour, depending on the chosen application and the product to be processed.

WORKING PRINCIPLE: After placing a loaded pallet on the machine, the pallet is lifted by movable hooks. Integrated hooks pick up the top layer of the pallet and then transport it over the rotating blades to the collection hopper. These rotating blades cut the bags and cause the granules to fall into the hopper. Thanks to the specially designed shaking method, the bag is completely emptied. The raw material discharge rate is better than 99.98%. After emptying the bags, the hooks automatically drop the empty bags into a collecting hopper.

With additional equipment (Bag Compactor), it is also possible to transport or drop empty bags into a bag compactor or baler.

The granule in the collecting hopper is automatically transported from the collecting hopper to the outer silos or to the desired point through the pneumatic conveying system. The bag unloading machine, including pneumatic raw material handling, is controlled by a completely independent "Siemens S7 PLC".



BAG OPENING AND EMPTYING MACHINE-BAGOMAX

t-max

ALTERNATIVE DESIGNS AND EXTRA OPTIONS:

- » XL unit: Suitable for dumping granulate into containers bigbags, octabins or truckloads
- » Automated cleaning: This machine can clean itself after a batch, so it is immediately ready for a different product
- » Automatic pallet transport (in and out)
- » Integrated palletstacker for stacking the empty pallets
- » Integrated bag compactor or baler for the empty bags

SPECIFICATION OF BAG EMPTYING MACHINE

- » Pallet dimensions: 1300mm x 1100mm (to be confirmed by customer)
- » Max. intake width: approx. 1400 mm
- » Pallet weight: approx. 1600 kg
- » Pallet height: max. 2200 mm (to be confirmed by customer)
- » Stacking: 5 bags per layer, stacked 3 by 2 in alternating directions, 11 layers
- » Capacity: approx. 15t/h (granulate) with > 99,98% discharge
- » Supply voltage: 3x 400V, 50Hz + earth
- » Protection rating: IP55
- » Control voltage: 24 VDC
- » Air consumption: 10 Normal-liter / cycle
- » Air conditioning: 6 bar dry conditioned air
- » Finishing: Frame: powder coated in RAL color
- » Total Load: 6.85 KW

Machine Dimensions	A	B	C	D	E	F	G	H
(MM)	6400	3300	1300	575	1490	400	2200	2600

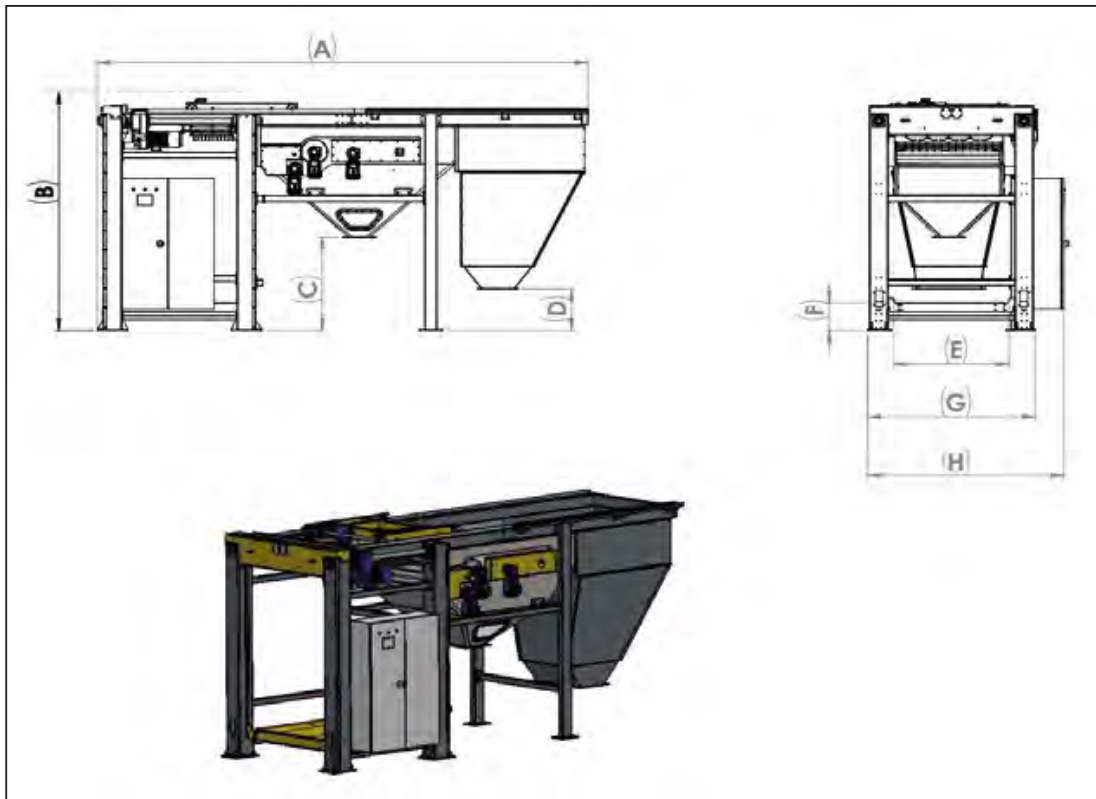



t-max

Tepro Makina ve Otomasyon Sistemleri San. ve Tic. A.Ş.
İnönü Mah. Gebze Güzeller OSB, Nursultan
Nazarbayev SK. No:14, 41400 Gebze / Kocaeli
+90 (216) 709 26 00

www.t-max.com.tr